

HFHG

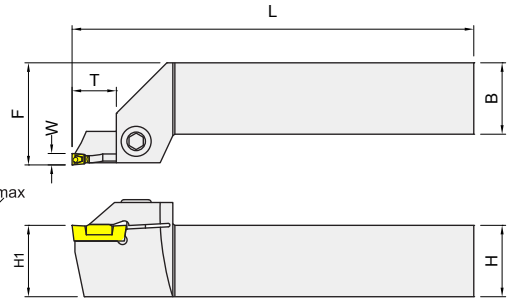
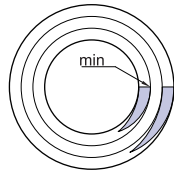
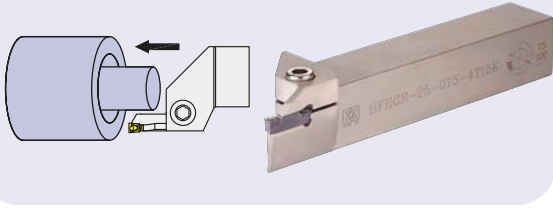

Right-hand shown

Item code	Dimensions,mm						Hole Diameter ØD		Insert	Screw	Wrench	Weight Kg
	H(H1)	B	L	F	W	T	min	max				
HFHGR-25-075-4T12K	25	25	150	35	4	12	75	100	HFPR40..	HTM622	PL50	0.73
HFHGR-25-075-4T15K						15			GRIP40..			0.73
HFHGR-25-098-4T15K	25	25	150	35	4	15	98	180		HTM630		0.73

STCP

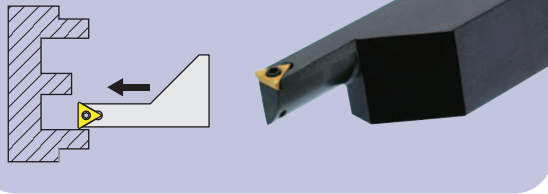

Left-shown (09L)

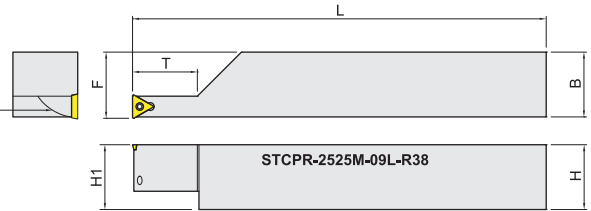

Right-hand shown (STCPR)

Item code	Dimensions,mm						Hole Diameter ØD		Insert	Screw	Wrench	Weight Kg
	H(H1)	B	L	F	W	T	min	max				
STCPR/L-2525M-09R-R38	25	25	150	25.5	9	25	76	∞	TP..0902	MS2506A	ETF09	0.78
STCPR/L-2525M-09L-R38												0.78

被切削材 Workpiece material	Steel 鋼	P	●	●	
	Stainless steel 不銹鋼	M	●	●	
	Cast iron 鑄鐵	K	●	●	●
	Non-ferrous metal 非鐵金屬	N			●

Insert Shape	Description	GRADE 材質			Dimensions,mm			
		Coated 塗層		Uncoated 無塗層	W	L	M	Re
		IC354	NW948	IC20				
	HFPR4004	●		●	4	19	2.8	0.4
	HFPR4020				4	19	2.8	2.0
	Description				A	S	d	Re
	TPMH090204MA		●		5.56	2.38	2.9	0.4