

Metric

Item code		Dimensions,mm				Teeth		Insert	Weight Kg
Right hand	Left hand	D	d	L	M				
ASX445-050A03R-22.0	ASX445-050A03L-22.0	50	22.0	40	11	3	疏齒 Coarse	SE..13T3..	0.54
ASX445-063A04R-22.0	ASX445-063A04L-22.0	63	22.0	40	11	4		WE..13T3..	0.82
ASX445-080B04R-27.0	ASX445-080B04L-27.0	80	27.0	50	38	4		1.40	
ASX445-100B05R-32.0	ASX445-100B05L-32.0	100	32.0	50	45	5		1.98	
ASX445-125B06R-40.0	ASX445-125B06L-40.0	125	40.0	63	60	6		3.10	
ASX445-160B07R-40.0	ASX445-160B07L-40.0	160	40.0	63	80	7		5.13	
ASX445-050A04R-22.0	ASX445-050A04L-22.0	50	22.0	40	11	4	密齒 Normal	SE..13T3..	0.50
ASX445-063A05R-22.0	ASX445-063A05L-22.0	63	22.0	40	11	5		WE..13T3..	0.76
ASX445-080B06R-27.0	ASX445-080B06L-27.0	80	27.0	50	38	6		1.31	
ASX445-100B07R-32.0	ASX445-100B07L-32.0	100	32.0	50	45	7		1.89	
ASX445-125B08R-40.0	ASX445-125B08L-40.0	125	40.0	63	60	8		3.01	
ASX445-160B10R-40.0	ASX445-160B10L-40.0	160	40.0	63	80	10		4.99	
ASX445-050A05R-22.0	ASX445-050A05L-22.0	50	22.0	40	11	5	超密齒 Close	SE..13T3..	0.50
ASX445-063A06R-22.0	ASX445-063A06L-22.0	63	22.0	40	11	6		WE..13T3..	0.80
ASX445-080B08R-27.0	ASX445-080B08L-27.0	80	27.0	50	38	8		1.30	
ASX445-100B10R-32.0	ASX445-100B10L-32.0	100	32.0	50	45	10		1.86	
ASX445-125B12R-40.0	ASX445-125B12L-40.0	125	40.0	63	60	12		2.97	
ASX445-160B16R-40.0	ASX445-160B16L-40.0	160	40.0	63	80	16		4.88	

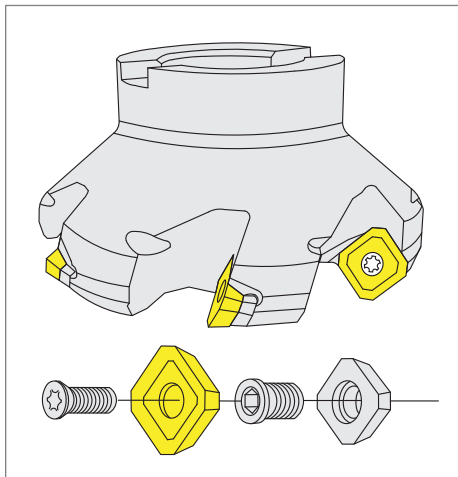

Shim	Screw	Wrench	Screw	Wrench
SSS445N	MDS05035S	PL35	MS3512B	ETF15

ASX 45° 面銑刀 45°FACE MILLING CUTTERS (ASX)



Inch

Item code		Dimensions,mm				Teeth	Insert	Weight Kg
Right hand	Left hand	D	d	L	M			
ASX445-R05003C-25.4	ASX445-L05003C-25.4	50	25.4	50	13	3	SE..13T3.. WE..13T3..	0.64
ASX445-R06304C-25.4	ASX445-L06304C-25.4	63	25.4	50	13	4		0.99
ASX445-R08004C-25.4	ASX445-L08004C-25.4	80	25.4	50	38	4		1.44
ASX445-R10005D-31.75	ASX445-L10005D-31.75	100	31.75	50	45	5		2.00
ASX445-R12506E-38.1	ASX445-L12506E-38.1	125	38.1	63	60	6		3.18
ASX445-R16007F-50.8	ASX445-L16007F-50.8	160	50.8	63	80	7		4.75
ASX445-R21008K-47.625	ASX445-L21008K-47.625	210	47.625	63	140	8		8.70
ASX445-R26010K-47.625	ASX445-L26010K-47.625	260	47.625	63	180	10		13.29
ASX445-R05004C-25.4	ASX445-L05004C-25.4	50	25.4	50	13	4	SE..13T3.. WE..13T3..	0.61
ASX445-R06305C-25.4	ASX445-L06305C-25.4	63	25.4	50	13	5		0.96
ASX445-R08006C-25.4	ASX445-L08006C-25.4	80	25.4	50	38	6		1.35
ASX445-R10007D-31.75	ASX445-L10007D-31.75	100	31.75	50	45	7		1.91
ASX445-R12508E-38.1	ASX445-L12508E-38.1	125	38.1	63	60	8		3.09
ASX445-R16010F-50.8	ASX445-L16010F-50.8	160	50.8	63	80	10		4.60
ASX445-R21012K-47.625	ASX445-L21012K-47.625	210	47.625	63	140	12		8.53
ASX445-R26014K-47.625	ASX445-L26014K-47.625	260	47.625	63	180	14		13.12
ASX445-R05005C-25.4	ASX445-L05005C-25.4	50	25.4	50	13	5	SE..13T3.. WE..13T3..	0.61
ASX445-R06306C-25.4	ASX445-L06306C-25.4	63	25.4	50	13	6		0.99
ASX445-R08008C-25.4	ASX445-L08008C-25.4	80	25.4	50	38	8		1.34
ASX445-R10010D-31.75	ASX445-L10010D-31.75	100	31.75	50	45	10		1.89
ASX445-R12512E-38.1	ASX445-L12512E-38.1	125	38.1	63	60	12		3.05
ASX445-R16016F-50.8	ASX445-L16016F-50.8	160	50.8	63	80	16		4.49

被切削材 Workpiece material	Steel 鋼	P	●	●	●		
	Stainless steel 不銹鋼	M		●	●		
	Cast iron 鑄鐵	K		●	●	●	●
	Non-ferrous metal 非鐵金屬	N				●	●

Insert Shape	Description	GRADE 材質					Dimensions,mm			
		Coated 塗層		Cermet 金屬陶瓷	Cemented Carbide 硬質合金		D	S	F	Re
		ACP200	NW948	NY942	H1	NM304				
	SEET13T3AGFN-L				○		13.4	3.97	2.5	--
	SEMT13T3AGSN-H	●					13.4	3.97	2.5	--
	SEGT13T3AGFN-JP					●	13.4	3.97	2.2	--
	SEMT13T3AGSN-JH		●				13.4	3.97	1.9	1.5
	WEEW13T3AGER8C						16.6	3.97	7.5	1.5
	WEEW13T3AGTR8C			●			16.6	3.97	7.5	1.5

內徑車刀
BORING BARS

外徑車刀
TOOLHOLDERS

牙刀 & 開槽刀
THREADING & GROOVING

銑刀
MILLING

孔加工
BORING TOOLS COMPONENTS

配件
SPARE PARTS