

功能：開槽 Grooving / 螺紋 Threading

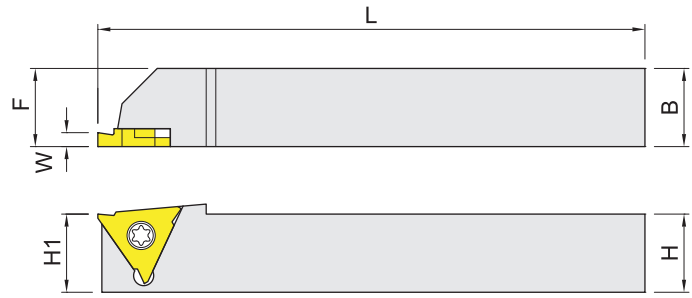

Right-hand shown

Item code	Dimensions,mm				Insert		Screw	Wrench	Weight Kg
	H (H1)	B	L	F	開槽刀片 Grooving	車牙刀片 Threading			
SGH2R-1212K-16	12	12	125	12	SMGTR 16X2... SMGTR 16X2...C	SMTTR 160360..	MS4008C	ETF10	0.15
SGH2R-1616K-16	16	16	125	16					0.26
SGH2R-2020K-16	20	20	125	20					0.42

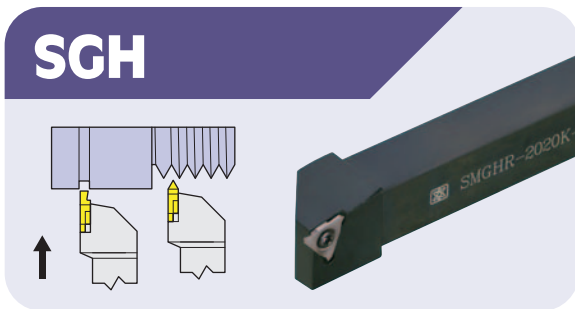

功能：開槽 Grooving / 螺紋 Threading

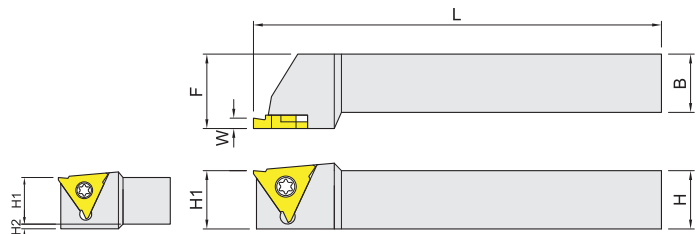

SGHR-1212K-16

Right-hand shown

Item code	Dimensions,mm					Insert		Screw	Wrench	Weight Kg
	H (H1)	B	L	H2	F	開槽刀片 Grooving	車牙刀片 Threading			
SGHR-1212K-16	12	12	125	2	16	SMGTR 16X2... SMGTR 16X2...C	SMTTR 160360..	MS4008C	ETF10	0.17
SGHR-1616K-16	16	16	125	--	20					0.29
SGHR-2020K-16	20	20	125	--	25					0.45
SGHR-2525M-16	25	25	150	--	32					0.84

※刀片請參考161頁 Please refer to page 161 for insert.

內徑車刀
BORING BARS

外徑車刀
TOOLHOLDERS

牙刀 & 開槽刀
THREADING & GROOVING

銑刀
MILLING

孔加工
BORING TOOLS COMPONENTS

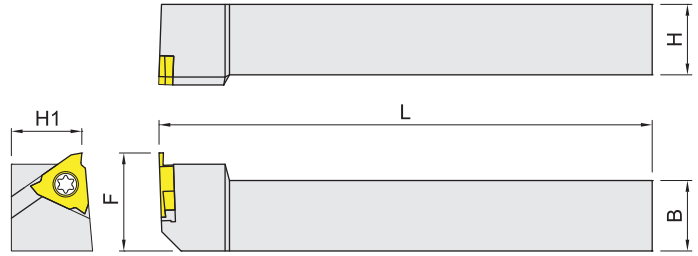
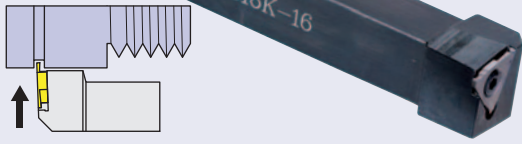

配件
SPARE PARTS

SGSL



Left-hand shown

功能：開槽 Grooving / 螺紋 Threading

Item code	Dimensions,mm				Insert		Screw 	Wrench 	Weight Kg
	H (H1)	B	L	F	開槽刀片 Grooving	車牙刀片 Threading			
SGSL-1616K-16	16	16	125	22	SMGTR 16X2...	SMTTR 160360..	MS4008C	ETF10	0.29
SGSL-2020K-16	20	20	125	26	SMGTR 16X2...C				0.45

被切削材 Workpiece material	Steel 鋼	P	●	●
	Stainless steel 不銹鋼	M	●	●
	Cast iron 鑄鐵	K	●	●
	Non-ferrous metal 非鐵金屬	N		

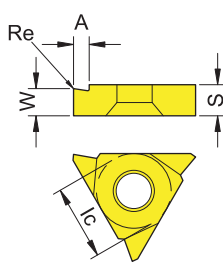
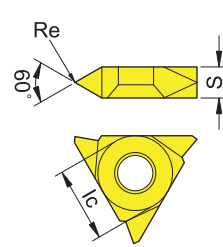
Insert Shape	Description	GRADE 材質		Dimensions,mm					
		Uncoated 無塗層		W	A	Ic	S	Re	Pitch(mm)
		NY942	NM936						
	SMGTR 16X2050			0.50	1.5	9.525	2.0	--	--
	16X2060			0.60				--	--
	16X2050C	●		0.50				0.05	--
	16X2060C	●		0.60					--
	16X2070C	●	●	0.70	2.0				--
	16X2075C	●		0.75					--
	16X2080C	●		0.80				0.1	--
	16X2095C	●		0.95					--
	16X2100C	●	●	1.00	2.5				--
	16X2110C	●		1.10					--
	16X2120C	●	●	1.20					--
	16X2130C	●		1.30					--
		SMTTR 16036001		●			9.525	3.18	0.1
16036002		●				9.525	3.18	0.2	1.75-2.0