

內徑車刀

BORING BARS

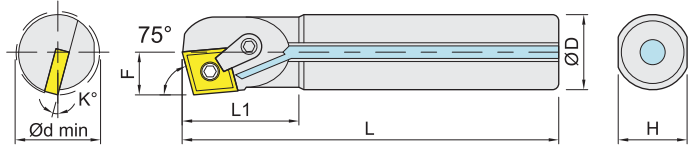

MCKN

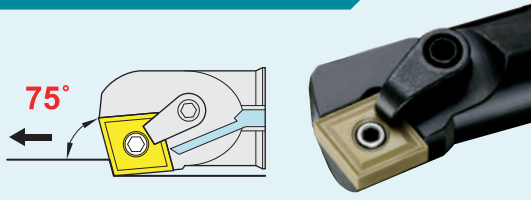

Coolant steel shank (right shown)
中心出水鋼柄 右向示意圖

Steel shank Item code		Dimensions,mm							Insert	Spare parts	Weight Kg
無水孔Non-coolant	水孔Coolant	D	L	L1	F	H	K	dmin			
S20R-MCKNR/L-12	A20R-MCKNR/L-12	20	200	40	13	18	15	25	CN..1204..	①	0.49
S25R-MCKNR/L-12	A25R-MCKNR/L-12	25	200	40	15.5	23	13	30			0.77
S32S-MCKNR/L-12	A32S-MCKNR/L-12	32	250	48	19.5	30	13	40	CN..1204..	②	1.58
S40T-MCKNR/L-12	A40T-MCKNR/L-12	40	300	55	25.5	37	12	50			2.96
S50U-MCKNR/L-12	A50U-MCKNR/L-12	50	350	60	30.5	47	10	60			5.40
S60V-MCKNR/L-12		60	400	60	35.5	57	9	70			8.88

Insert	Spare parts	Shim	Pin	Wrench	Clamp	Screw	Wrench
CN..1204..	①	--	MLP44-A	PL25	MC620	MS620TX	ETL15
CN..1204..	②	CMS432	MLP46-A	PL25	MC620	MS625TX	ETL15

DCLN

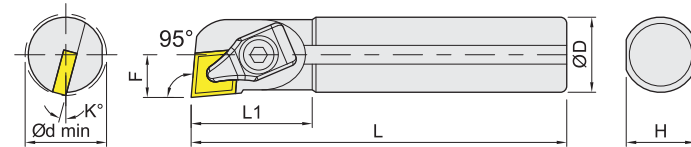

Steel shank (right shown)
鋼柄 右向示意圖

Steel shank Item code		Dimensions,mm							Insert	Spare parts	Weight Kg
無水孔Non-coolant	水孔Coolant	D	L	L1	F	H	K	dmin			
S20R-DCLNR/L-12		20	200	40	14	18	15	28	CN..1204..	①	0.49
S25R-DCLNR/L-12		25	200	40	15	23	13	30			0.77
S32S-DCLNR/L-12		32	250	48	19.5	30	13	40	CN..1204..	②	1.58

Insert	Spare parts	Shim	Screw	Wrench	Clamp	Wrench
CN..1204..	①	--	--	--	MCD425	ETL20
CN..1204..	②	CMS432	MS6013F	PL40	MCD425	ETL20

MCLN

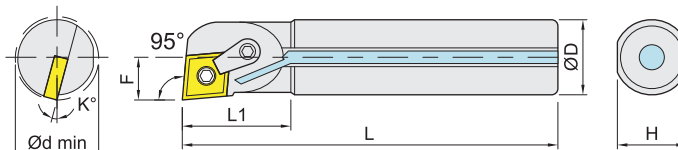
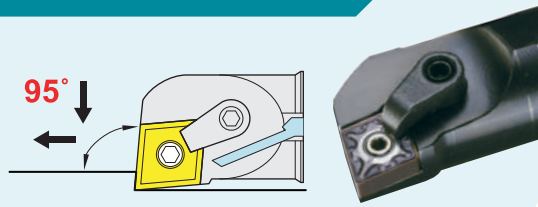

Coolant steel shank (right shown)
中心出水鋼柄 右向示意圖

Steel shank Item code		Dimensions,mm							Insert	Spare parts	Weight Kg
無水孔Non-coolant	水孔Coolant	D	L	L1	F	H	K	dmin			
S20R-MCLNR/L-12	A20R-MCLNR/L-12	20	200	40	13	18	15	25	CN..1204..	①	0.49
S25R-MCLNR/L-12	A25R-MCLNR/L-12	25	200	40	15.5	23	13	30			0.77
S32S-MCLNR/L-12	A32S-MCLNR/L-12	32	250	48	19.5	30	13	40	CN..1204..	②	1.58
S40T-MCLNR/L-12	A40T-MCLNR/L-12	40	300	55	25.5	37	12	50			2.96
S50U-MCLNR/L-12		50	350	60	30.5	47	10	60			5.40
S60V-MCLNR/L-12	A60V-MCLNR/L-12	60	400	60	35.5	57	9	70			8.88

Insert	Spare parts	Shim	Pin	Wrench	Clamp	Screw	Wrench
CN..1204..	①	--	MLP44-A	PL25	MC620	MS620TX	ETL15
CN..1204..	②	CMS432	MLP46-A	PL25	MC620	MS625TX	ETL15

MSKN

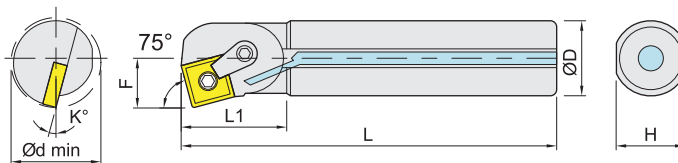
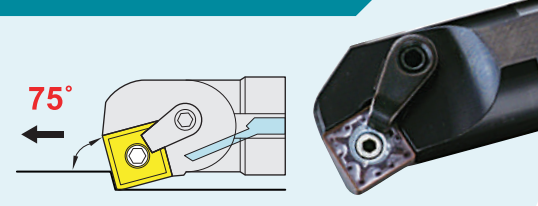

Coolant steel shank (right shown)
中心出水鋼柄 右向示意圖

Steel shank Item code		Dimensions,mm							Insert	Spare parts	Weight Kg
無水孔Non-coolant	水孔Coolant	D	L	L1	F	H	K	dmin			
S25R-MSKNR/L-12	A25R-MSKNR/L-12	25	200	40	15	23	13	30	SN..1204..	①	0.77
S32S-MSKNR/L-12	A32S-MSKNR/L-12	32	250	48	19.5	30	13	40			1.58
S40T-MSKNR/L-12		40	300	55	25.5	37	12	50	SN..1204..	②	2.96
S50U-MSKNR/L-12		50	350	60	30.5	47	10	60			5.40
S60V-MSKNR/L-12		60	400	60	36	57	9	70			8.88

Insert	Spare parts	Shim	Pin	Wrench	Clamp	Screw	Wrench
SN..1204..	①	--	MLP44-A	PL25	MC620	MS620TX	ETL15
SN..1204..	②	SMS432	MLP46-A	PL25	MC620	MS625TX	ETL15

內徑車刀
BORING BARS

外徑車刀
TOOL HOLDERS

牙刀 & 開槽刀
THREADING & GROOVING

銑刀
MILLING

孔加工
BORING TOOLS COMPONENTS

配件
SPARE PARTS

DDUN

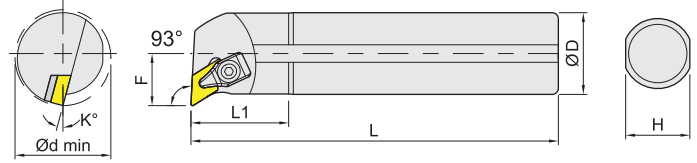
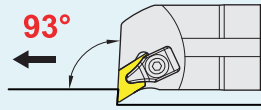

Steel shank (right shown)
鋼柄 右向示意圖

Steel shank Item code		Dimensions,mm							Insert	Spare parts	Weight Kg
無水孔Non-coolant	水孔Coolant	D	L	L1	F	H	K	dmin			
S32S-DDUNR-1504		32	250	50	20	30	13	38	DN..1504..	①	1.58
S40S-DDUNR/L-1504		40	250	50	25.5	37	10	48		②	2.37
NEW S50U-DDUNR/L-1504		50	350	60	30.5	47	10	58		②	5.27
S32S-DDUNR-1506		32	250	50	20	30	13	38	DN..1506..	③	1.58
S40S-DDUNR-1506		40	250	50	25.5	37	10	48		④	2.37
NEW S50U-DDUNR/L-1506		50	350	60	30.5	47	10	58		④	5.27

Insert	Spare parts	Shim	Screw	Wrench	Clamp	Wrench
DN..1504..	①	DMS432	MS6013F	PL40	MCD425	ETL20
DN..1504..	②	DMS442				
DN..1506..	③	DPS422	MS6010G	ETL15		
DN..1506..	④	DMS432	MS6013F	PL40		

※此刀架本體共用。The tool is basically the same, only difference in shims.

MDUN

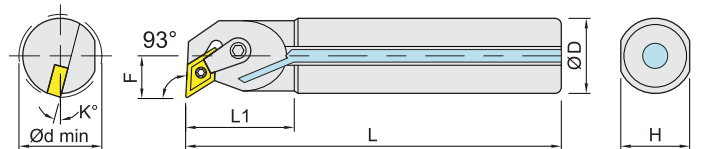
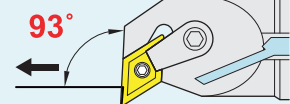

Coolant steel shank (right shown)
中心出水鋼柄 右向示意圖

Steel shank Item code		Dimensions,mm							Insert	Spare parts	Weight Kg
無水孔Non-coolant	水孔Coolant	D	L	L1	F	H	K	dmin			
S25R-MDUNR/L-15	A25R-MDUNR/L-15	25	200	45	17	23	13	32	DN..1504..	①	0.77
S32S-MDUNR/L-15	A32S-MDUNR/L-15	32	250	50	21	30	13	40		②	1.58

Insert	Spare parts	Shim	Pin	Wrench	Clamp	Screw	Wrench
DN..1504..	①	--	MLP44-A	PL25	MC620	MS620TX	ETL15
DN..1504..	②	DMS432	MLP46-A	PL25	MC620	MS625TX	ETL15

MTQN

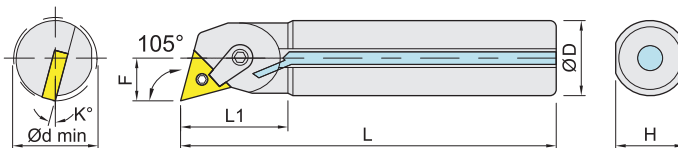
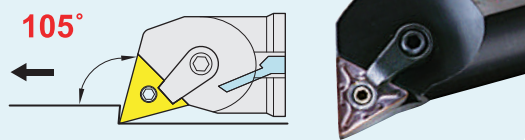

Coolant steel shank (right shown)
中心出水鋼柄 右向示意圖

Steel shank Item code		Dimensions,mm							Insert	Spare parts	Weight Kg
無水孔Non-coolant	水孔Coolant	D	L	L1	F	H	K	dmin			
S20R-MTQNR/L-16	A20R-MTQNR/L-16	20	200	40	13	18	15	25	TN..1604..	①	0.49
S25R-MTQNR/L-16	A25R-MTQNR/L-16	25	200	40	15	23	13	30			0.77
S32S-MTQNR/L-16	A32S-MTQNR/L-16	32	250	48	20	30	13	40		②	1.58

Insert	Spare parts	Shim	Pin	Wrench	Clamp	Screw	Wrench
TN..1604..	①	--	MLP33L-A	PL20	MC515	MS520TX	ETL10
TN..1604..	②	TMS322	MLP34L-A	PL20	MC620	MS625TX	ETL15

DTUN

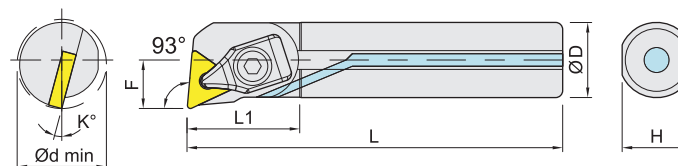
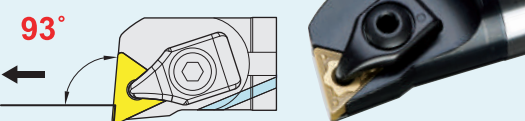

Coolant steel shank (right shown)
中心出水鋼柄 右向示意圖

Steel shank Item code		Dimensions,mm							Insert	Spare parts	Weight Kg
無水孔Non-coolant	水孔Coolant	D	L	L1	F	H	K	dmin			
S20R-DTUNR/L-16	A20R-DTUNR/L-16	20	200	40	14	18	15	28	TN..1604..	①	0.49
S25R-DTUNR/L-16	A25R-DTUNR/L-16	25	200	40	15.5	23	13	30			0.77
S25S-DTUNR/L-16		25	250	40	15.5	23	13	30		0.96	
S32S-DTUNR/L-16	A32S-DTUNR/L-16	32	250	48	19.5	30	13	40	TN..1604..	②	1.58
NEW S40U-DTUNR/L-16		40	350	55	25.5	37	10	50			3.45
NEW S50V-DTUNR/L-16		50	400	60	30.5	47	10	60			6.17

Insert	Spare parts	Shim	Screw	Wrench	Clamp	Wrench
TN..1604..	①	--	--	--	MCD324	ETL20
TN..1604..	②	TWS322	MS4008H	PL25	MCD324B	PL40

內徑車刀
BORING BARS

外徑車刀
TOOL HOLDERS

牙刀 & 開槽刀
THREADING & GROOVING

銑刀
MILLING

孔加工
BORING TOOLS COMPONENTS

配件
SPARE PARTS

MTUN

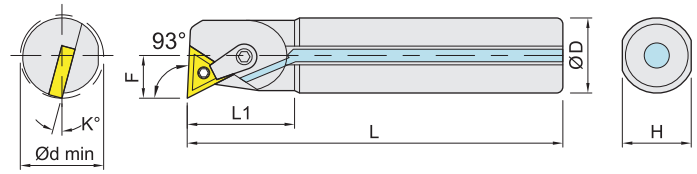
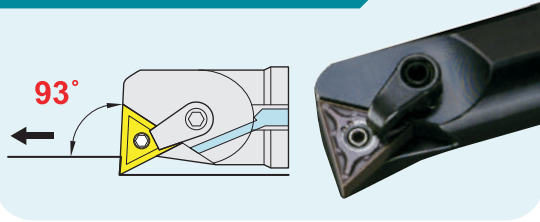

Coolant steel shank (right shown)
中心出水鋼柄 右向示意圖

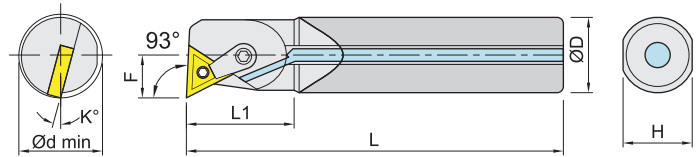

Coolant carbide shank (right shown)
中心出水鎢鋼柄 右向示意圖

Steel shank Item code		Dimensions,mm							Insert	Spare parts	Weight Kg
無水孔Non-coolant	水孔Coolant	D	L	L1	F	H	K	dmin			
S20R-MTUNR/L-16	A20R-MTUNR/L-16	20	200	40	13	18	15	25	TN..1604..	①	0.49
S25R-MTUNR/L-16	A25R-MTUNR/L-16	25	200	40	15.5	23	13	30			0.77
S32S-MTUNR/L-16	A32S-MTUNR/L-16	32	250	48	19.5	30	13	40	TN..1604..	②	1.58
S40T-MTUNR/L-16	A40T-MTUNR/L-16	40	300	55	25.5	37	10	50			2.96
S50U-MTUNR/L-16	A50U-MTUNR-16	50	350	60	30.5	47	9	60			5.40
S50V-MTUNR/L-16	A50V-MTUNR-16	50	400	60	30.5	47	9	60			6.17
S60U-MTUNR/L-16		60	350	60	35.5	57	8	70			7.77
S60V-MTUNR/L-16		60	400	60	35.5	57	8	70			8.88

Carbide shank Item code		Dimensions,mm							Insert	Spare parts	Weight Kg
無水孔Non-coolant	水孔Coolant	D	L	L1	F	H	K	dmin			
C20S-MTUNR/L-16		20	250	40	13	18	15	25	TN..1604..	①	0.49
C25S-MTUNR/L-16	E25S-MTUNR/L-16	25	250	40	15.5	23	13	30			0.77

Insert	Spare parts	Shim	Pin	Wrench	Clamp	Screw	Wrench
TN..1604..	①	--	MLP33L-A	PL20	MC515	MS520TX	ETL10
TN..1604..	②	TMS322	MLP34L-A	PL20	MC620	MS625TX	ETL15

BORING BARS
內徑車刀

TOOLHOLDERS
外徑車刀

THREADING & GROOVING
牙刀 & 開槽刀

MILLING
銑刀

BORING TOOLS COMPONENTS
孔加工

SPARE PARTS
配件

WTUN

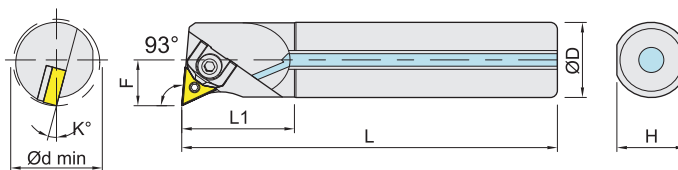
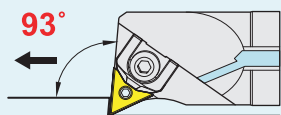

Coolant steel shank (right shown)
中心出水鋼柄 右向示意圖

Steel shank Item code		Dimensions,mm							Insert	Spare parts	Weight Kg
無水孔Non-coolant	水孔Coolant	D	L	L1	F	H	K	dmin			
S32S-WTUNR/L-16	A32S-WTUNR/L-16	32	250	48	19.5	30	13	40	TN..1604..	①	1.58
S40T-WTUNR/L-16	A40T-WTUNR/L-16	40	300	55	25.5	37	10	50	TN..1604..	②	2.96
S40U-WTUNR/L-16	A40U-WTUNR/L-16	40	350	55	25.5	37	10	50			3.45
S50U-WTUNR/L-16		50	350	60	30.5	47	9	60			5.40
S50V-WTUNR/L-16		50	400	60	30.5	47	9	60			6.17
S60U-WTUNR/L-16		60	350	60	35.5	57	8	70			7.77
S60V-WTUNR/L-16	A60V-WTUNR/L-16	60	400	60	35.5	57	8	70			8.88

Insert	Spare parts	Shim	Pin	Clamp	Wrench
TN..1604..	①	TMS322	SCP315	MCW3-P25	PL25
TN..1604..	②	TMS322	SCP318	MCW3-P25	PL25

MTWN

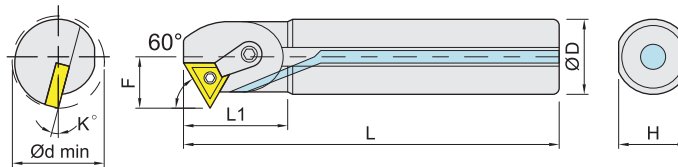
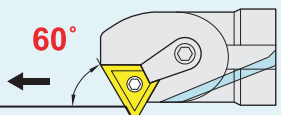

Coolant steel shank (right shown)
中心出水鋼柄 右向示意圖

Steel shank Item code		Dimensions,mm							Insert	Spare parts	Weight Kg
無水孔Non-coolant	水孔Coolant	D	L	L1	F	H	K	dmin			
S20R-MTWNR/L-16	A20R-MTWNR-16	20	200	40	13.5	18	15	27	TN..1604..	①	0.49
S25R-MTWNR/L-16	A25R-MTWNR/L-16	25	200	40	16	23	13	32			0.77
S32S-MTWNR/L-16	A32S-MTWNR/L-16	32	250	48	20	30	13	40	TN..1604..	②	1.58

Insert	Spare parts	Shim	Pin	Wrench	Clamp	Screw	Wrench
TN..1604..	①	--	MLP33L-A	PL20	MC515	MS520TX	ETL10
TN..1604..	②	TMS322	MLP34L-A	PL20	MC620	MS625TX	ETL15

內徑車刀
BORING BARS

外徑車刀
TOOL HOLDERS

牙刀 & 開槽刀
THREADING & GROOVING

銑刀
MILLING

孔加工
BORING TOOLS COMPONENTS

配件
SPARE PARTS

DVUN

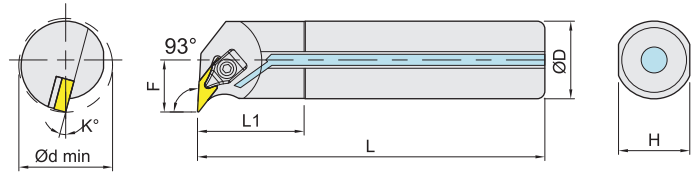
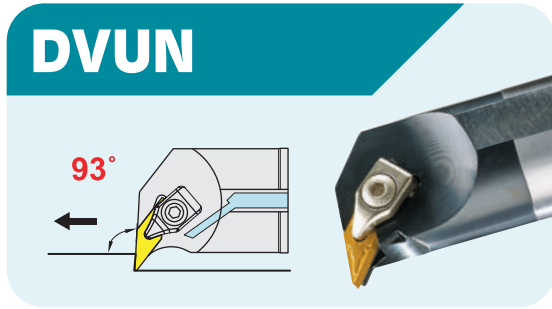

Coolant steel shank (right shown)
中心出水鋼柄 右向示意圖

Steel shank Item code		Dimensions,mm							Insert	Spare parts	Weight Kg
無水孔Non-coolant	水孔Coolant	D	L	L1	F	H	K	dmin			
S40T-DVUNR/L-16	A40T-DVUNR/L-16	40	300	55	26	37	10	50	VN..1604..	①	2.96
S40V-DVUNR/L-16	A40V-DVUNR/L-16	40	400	55	26	37	10	50			3.95
S50V-DVUNR/L-16	A50V-DVUNR/L-16	50	400	60	32	47	9	60			6.17

Insert	Spare parts	Shim	Screw	Wrench	Clamp	Wrench
VN..1604..	①	VMS322	MDS050H65T	PL35	MCD324B	ETL20

MVUN

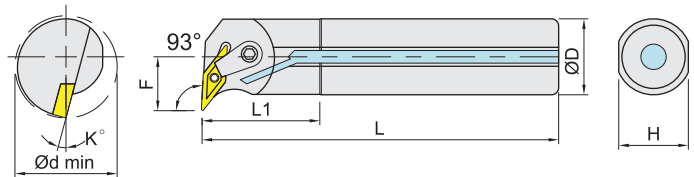
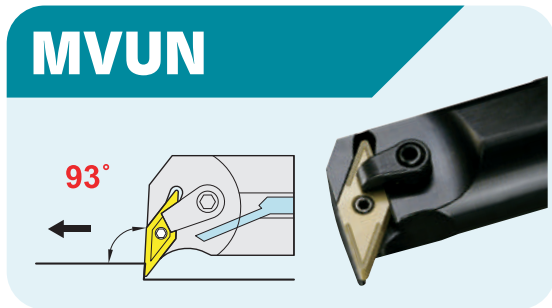

Coolant steel shank (right shown)
中心出水鋼柄 右向示意圖

Steel shank Item code		Dimensions,mm							Insert	Spare parts	Weight Kg
無水孔Non-coolant	水孔Coolant	D	L	L1	F	H	K	dmin			
S25R-MVUNR/L-16	A25R-MVUNR/L-16	25	200	45	18	23	13	32	VN..1604..	①	0.77
S32S-MVUNR/L-16	A32S-MVUNR/L-16	32	250	50	21	30	13	40	VN..1604..		②
S40T-MVUNR/L-16	A40T-MVUNR/L-16	40	300	55	26	37	10	50	VN..1604..	②	2.96
S50U-MVUNR/L-16	A50U-MVUNR/L-16	50	350	60	32	47	9	60			5.40

Insert	Spare parts	Shim	Pin	Wrench	Clamp	Screw	Wrench
VN..1604..	①	--	MLP33L-A	PL20	MC515	MS520TX	ETL10
VN..1604..	②	VMS322	MLP34L-A	PL20	MC620	MS625TX	ETL15

BORING BARS
內徑車刀

TOOLHOLDERS
外徑車刀

THREADING & GROOVING
牙刀 & 開槽刀

MILLING
銑刀

BORING TOOLS COMPONENTS
孔加工

SPARE PARTS
配件

DWLN

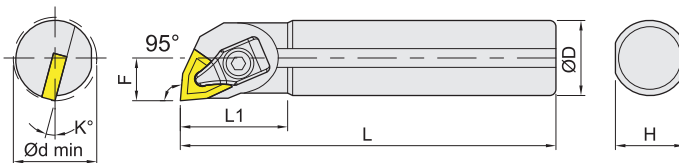
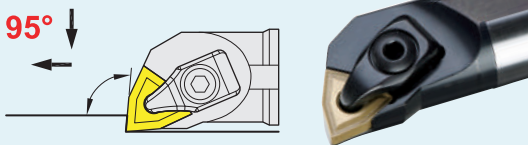

Steel shank (right shown)
鋼柄 右向示意圖

Steel shank Item code		Dimensions,mm							Insert	Spare parts	Weight Kg
無水孔Non-coolant	水孔Coolant	D	L	L1	F	H	K	dmin			
S20R-DWLN /L-08	--	20	200	40	14	18	15	28	WN..0804..	①	0.49
S25R-DWLN /L-08	--	25	200	40	15	23	13	30			0.77
S32S-DWLN /L-08	--	32	250	48	19.5	30	13	40	WN..0804..	②	1.58
S40T-DWLN /L-08	--	40	300	55	25.5	37	11	50			2.96

Insert	Spare parts	Shim	Screw	Wrench	Clamp	Wrench
WN..0804..	①	--	--	--	MCD425	ETL20
WN..0804..	②	WMS432	MS6013F	PL40	MCD425	ETL20

MWLN

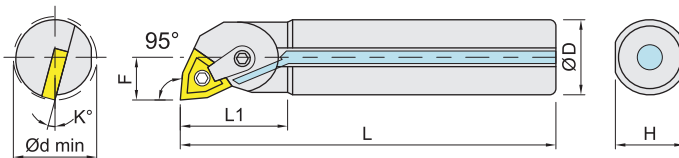
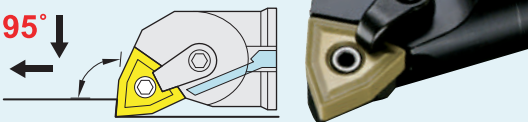

Coolant steel shank (right shown)
中心出水鋼柄 右向示意圖

Steel shank Item code		Dimensions,mm							Insert	Spare parts	Weight Kg
無水孔Non-coolant	水孔Coolant	D	L	L1	F	H	K	dmin			
S20R-MWLN /L-08	A20R-MWLN /L-08	20	200	40	13	18	15	25	WN..0804..	①	0.49
S25R-MWLN /L-08	A25R-MWLN /L-08	25	200	40	15	23	13	30			0.77
S32S-MWLN /L-08	A32S-MWLN /L-08	32	250	48	20	30	13	40	WN..0804..	②	1.58
S40T-MWLN /L-08	A40T-MWLN /L-08	40	300	55	25.5	37	10	50	WN..0804..	③	2.96
S50U-MWLN /L-08		50	350	60	30.5	47	9	60			5.40
S50V-MWLN /L-08	A50V-MWLN /L-08	50	400	60	30.5	47	9	60			6.17
S60V-MWLN /L-08		60	400	60	35.5	57	8	70			8.88

Insert	Spare parts	Shim	Pin	Wrench	Clamp	Screw	Wrench
WN..0804..	①	--	MLP44-A	PL25	MC515	MS520TX	ETL10
WN..0804..	②	WMS432	MLP46-A	PL25	MC515	MS520TX	ETL10
WN..0804..	③	WMS432	MLP46-A	PL25	MC620	MS625TX	ETL15

內徑車刀
BORING BARS

外徑車刀
TOOL HOLDERS

牙刀 & 開槽刀
THREADING & GROOVING

銑刀
MILLING

孔加工
BORING TOOLS COMPONENTS

配件
SPARE PARTS

SCLC

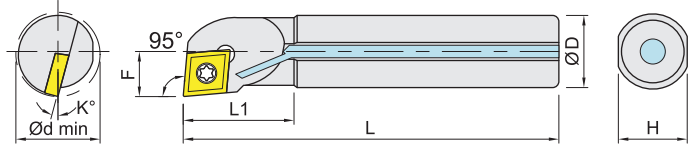
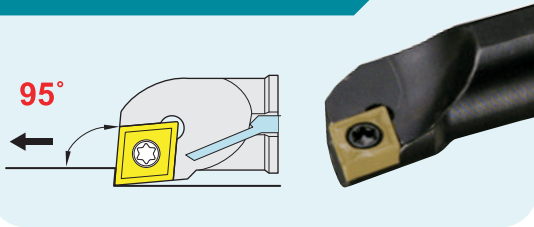

Coolant steel shank (right shown)
中心出水鋼柄 右向示意圖

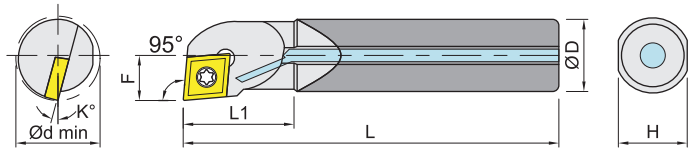

Coolant carbide shank (right shown)
中心出水鎢鋼柄 右向示意圖

BORING BARS
內徑車刀

TOOLHOLDERS
外徑車刀

THREADING & GROOVING
牙刀 & 開槽刀

MILLING
銑刀

BORING TOOLS COMPONENTS
孔加工

SPARE PARTS
配件

Steel shank Item code		Dimensions,mm							Insert	Spare parts	Weight Kg		
無水孔Non-coolant	水孔Coolant	D	L	L1	F	H	K	dmin					
S08K-SCLCR/L-06	A08K-SCLCR/L-06	8	125	20	5	7	15	10	CC..0602..	③	0.07		
S08K-SCLCR/L-06-D09	A08K-SCLCR/L-06-D09	8	125	20	4.5	7	15	9			0.07		
S10K-SCLCR/L-06	A10K-SCLCR/L-06	10	125	22	6	9	13	12			0.09		
S10K-SCLCR/L-06-D11	A10K-SCLCR/L-06-D11	10	125	22	5.5	9	13	11			0.09		
S12M-SCLCR/L-06	A12M-SCLCR/L-06	12	150	26	8	11	10	16			0.13		
S12M-SCLCR/L-06-D13	A12M-SCLCR/L-06-D13	12	150	26	6.5	11	10	13			0.13		
S14Q-SCLCR/L-06	A14Q-SCLCR/L-06	14	180	26	8	13	10	16			0.22		
S16Q-SCLCR/L-06	A16Q-SCLCR/L-06	16	180	32	10	15	7	20			0.28		
S12M-SCLCR/L-09	A12M-SCLCR/L-09	12	150	26	8	11	10	16			CC..09T3..	④	0.13
S14Q-SCLCR/L-09	A14Q-SCLCR/L-09	14	180	26	8	13	10	16					0.22
S15Q-SCLCR/L-09	A15Q-SCLCR/L-09	15	180	32	8.5	14	10	17	0.25				
S16Q-SCLCR/L-09	A16Q-SCLCR/L-09	16	180	32	10	15	7	20	0.28				
S16Q-SCLCR/L-09-D18	A16Q-SCLCR/L-09-D18	16	180	32	9	15	7	18	0.28				
S18Q-SCLCR/L-09	A18Q-SCLCR/L-09	18	180	32	10	17	7	20	0.36				
S20R-SCLCR/L-09	A20R-SCLCR/L-09	20	200	40	13	18	5	25	⑤	0.49			
S22R-SCLCR -09		22	200	40	13	20	5	25		0.60			
S25R-SCLCR/L-09	A25R-SCLCR/L-09	25	200	40	15	23	5	30	⑥	0.77			
S32S-SCLCR/L-09	A32S-SCLCR/L-09	32	250	48	19.5	30	5	38		1.58			
S32S-SCLCR/L-12	A32S-SCLCR/L-12	32	250	48	20	30	5	38	CC..1204..	⑦	1.58		
S40T-SCLCR/L-12	A40T-SCLCR/L-12	40	300	55	26	37	3	50			2.96		
S40V-SCLCR/L-12	A40V-SCLCR/L-12	40	400	55	26	37	3	50			3.95		

Carbide shank Item code		Dimensions,mm							Insert	Spare parts	Weight Kg
無水孔Non-coolant	水孔Coolant	D	L	L1	F	H	K	dmin			
C04H-SCLCR/L-03M	-	4	100	15	2.5	3.7	15	5	CC..03S1..	①	0.02
C05H-SCLCR/L-03M	-	5	100	15	3	4.7	15	6			0.03
C06J-SCLCR/L-04K	-	6	110	15	3.5	5.7	15	7	CC..0401..	②	0.05
C07J-SCLCR/L-06	-	7	110	18	4	6.7	15	8			0.06
C08K-SCLCR/L-06	-	8	125	20	5	7.2	15	10	CC..0602..	③	0.09
C08K-SCLCR/L-06-D09	E08K-SCLCR-06-D09	8	125	20	4.5	7.2	15	9			0.09
	E08M-SCLCR-06	8	150	20	5	7.2	15	10			0.11
C10K-SCLCR/L-06	E10K-SCLCR/L-06	10	125	22	6	9.2	13	12			0.14
C10K-SCLCR/L-06-D11	E10K-SCLCR-06-D11	10	125	22	5.5	9.2	13	11			0.14
C10M-SCLCR/L-06	E10M-SCLCR/L-06	10	150	22	6	9.2	13	12			0.17
C10M-SCLCR-06-D11	E10M-SCLCR-06-D11	10	150	22	5.5	9.2	13	11			0.17
C12M-SCLCR/L-06	E12M-SCLCR-06	12	150	26	8	11.2	10	16			0.24
C12M-SCLCR/L-06-D13	E12M-SCLCR-06-D13	12	150	26	6.5	11.2	10	13			0.24
C12Q-SCLCR/L-06	E12Q-SCLCR-06	12	180	26	8	11.2	10	16			0.29
C12Q-SCLCR-06-D13	E12Q-SCLCR-06-D13	12	180	26	6.5	11.2	10	13			0.29
C14R-SCLCR-06		14	200	26	8	13.2	10	16			0.44
C16R-SCLCR/L-06	E16R-SCLCR-06	16	200	32	10	15.2	7	20			0.58
C12M-SCLCR/L-09	E12M-SCLCR-09	12	150	26	8	11.2	10	16	CC..09T3..	④	0.24
C12Q-SCLCR/L-09		12	180	26	8	11.2	10	16			0.29
C14R-SCLCR-09		14	200	26	8	13.2	10	16			0.44
C16R-SCLCR/L-09	E16R-SCLCR/L-09	16	200	32	10	15.2	7	20			0.58
C16R-SCLCR-09-D18	E16R-SCLCR-09-D18	16	200	32	9	15.2	7	18			0.58
C20R-SCLCR/L-09	E20R-SCLCR-09	20	200	40	13	19.2	5	25	CC..09T3..	⑤	0.91
C25S-SCLCR/L-09	E25S-SCLCR-09	25	250	40	15	24.2	5	30	CC..09T3..	⑥	1.77

※ 鎢鋼柄Ø7以下刀桿僅一面側固(Carbide shank below Ø7 is one weldon flat only)。

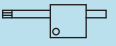
Insert	Spare parts	Screw 	Wrench 
CC..03S1..	①	MS1603B	ETF06
CC..0401..	②	MS2004A	ETF06
CC..0602..	③	MS2506A	ETF09
CC..09T3..	④	MS4008A	ETF15
CC..09T3..	⑤	MS4009A	ETF15
CC..09T3..	⑥	MS4011A	ETF15
CC..1204..	⑦	MS5011A	ETF20

C10K-SCLCR-06

S=鋼柄(Steel shank)

A=鋼柄+出水(Steel shank+coolant hole)

C=鎢鋼柄(Cemented carbide shank with steel head)

E=鎢鋼柄+出水(Cemented carbide shank with steel head+coolant hole)

內徑車刀
BORING BARS

外徑車刀
TOOL HOLDERS

牙刀 & 開槽刀
THREADING & GROOVING

銑刀
MILLING

孔加工
BORING TOOLS COMPONENTS

配件
SPARE PARTS

SCLP

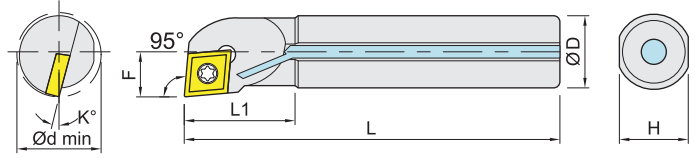
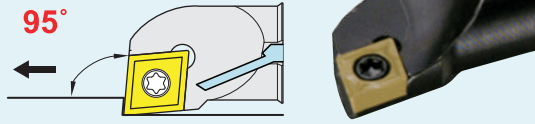

Coolant steel shank (right shown)
中心出水鋼柄 右向示意圖

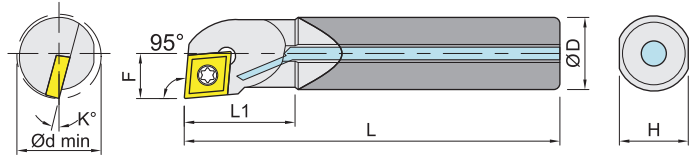

Coolant carbide shank (right shown)
中心出水鎢鋼柄 右向示意圖

Steel shank Item code		Dimensions,mm							Insert	Spare parts	Weight Kg
無水孔Non-coolant	水孔Coolant	D	L	L1	F	H	K	dmin			
S08K-SCLPR/L-06	A08K-SCLPR/L-06	8	125	20	5	7	10	10	CP..0602..	①	0.07
S10K-SCLPR/L-06	A10K-SCLPR/L-06	10	125	22	6	9	8	12			0.09
S12M-SCLPR/L-06	-	12	150	26	8	11	7	16			0.13
S10K-SCLPR/L-08	A10K-SCLPR/L-08	10	125	22	6	9	8	12	CP..0802..	②	0.09
S12M-SCLPR/L-08	A12M-SCLPR/L-08	12	150	26	8	11	7	16			0.13
S12M-SCLPR/L-08-D13	A12M-SCLPR/L-08-D13	12	150	26	6.5	11	7	13			0.13
S12M-SCLPR/L-09	A12M-SCLPR/L-09	12	150	26	8	11	7	16	CP..0903..	④	0.13
S16Q-SCLPR/L-09	A16Q-SCLPR/L-09	16	180	32	10	15	7	20			0.28
S16Q-SCLPR-09-D18	A16Q-SCLPR-09-D18	16	180	32	9	15	7	18			0.28
S20R-SCLPR/L-09	A20R-SCLPR/L-09	20	200	40	13	18	4	25	⑤	0.49	
S25R-SCLPR/L-09	A25R-SCLPR/L-09	25	200	40	15	23	0	30			0.77

BORING BARS
內徑車刀

TOOL HOLDERS
外徑車刀

THREADING & GROOVING
牙刀 & 開槽刀

MILLING
銑刀

BORING TOOLS COMPONENTS
孔加工

SPARE PARTS
配件

Carbide shank		Item code		Dimensions,mm					Insert	Spare parts	Weight Kg
無水孔Non-coolant	水孔Coolant	D	L	L1	F	H	K	dmin			
C10K-SCLPR-08		10	125	22	6	9.2	8	12	CP..0802..	②	0.14
C10M-SCLPR/L-08		10	150	22	6	9.2	8	12			0.17
C12M-SCLPR-08		12	150	26	8	11.2	7	16		③	0.24
C12M-SCLPR-09	E12M-SCLPR-09	12	150	26	8	11.2	7	16	CP..0903..	④	0.24
C12Q-SCLPR-09	E12Q-SCLPR-09	12	180	26	8	11.2	7	16			0.29
C16R-SCLPR/L-09	E16R-SCLPR/L-09	16	200	32	10	15.2	7	20			0.58
C16R-SCLPR-09-D18	E16R-SCLPR-09-D18	16	200	32	9	15.2	7	18			0.58
C20R-SCLPR-09	E20R-SCLPR-09	20	200	40	13	19.2	4	25			⑤
C25S-SCLPR/L-09		25	250	40	15	24.2	0	30		1.77	

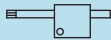
Insert	Spare parts	Screw 	Wrench 
CP..0602..	①	MS2506A	ETF09
CP..0802..	②	MS3006A	ETF09
CP..0802..	③	MS3008A	ETF09
CP..0903..	④	MS4008B	ETF15
CP..0903..	⑤	MS4009B	ETF15

E16R-SCLPR-09	S=鋼柄(Steel shank)
	A=鋼柄+出水(Steel shank+coolant hole)
	C=鎢鋼柄(Cemented carbide shank with steel head)
	E=鎢鋼柄+出水(Cemented carbide shank with steel head+coolant hole)

內徑車刀
BORING BARS

外徑車刀
TOOL HOLDERS

牙刀 & 開槽刀
THREADING & GROOVING

銑刀
MILLING

孔加工
BORING TOOLS COMPONENTS

配件
SPARE PARTS

SCLC/P

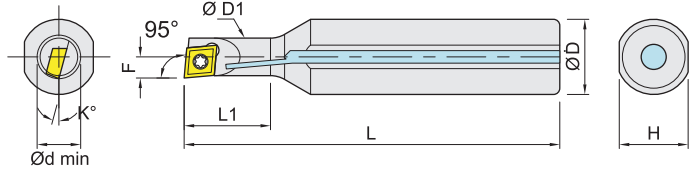
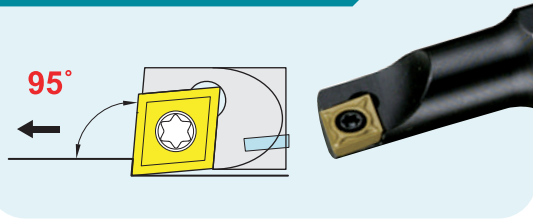

Coolant steel shank (right shown)
中心出水鋼柄 右向示意圖

BORING BARS
內徑車刀

TOOLHOLDERS
外徑車刀

THREADING & GROOVING
牙刀 & 開槽刀

MILLING
銑刀

BORING TOOLS COMPONENTS
孔加工

SPARE PARTS
配件

Steel shank Item code		Dimensions,mm								Insert	Spare parts	Weight Kg
無水孔 Non-coolant	水孔 Coolant	D	D1	L	L1	F	H	K	dmin			
S1004K-SCLCR/L-03M	A1004K-SCLCR/L-03M	10	4	125	12	2.5	9	15	5	CC..03S1..	①	0.08
S1005K-SCLCR/L-03M	A1005K-SCLCR/L-03M	10	5	125	15	3	9	15	6			0.08
S1204H-SCLCR/L-03E-L08	A1204H-SCLCR/L-03E-L08	12	4	100	8	2.5	11	15	5	CC..0301..	②	0.09
S1204H-SCLCR/L-03E-L12	A1204H-SCLCR/L-03E-L12	12	4	100	12	2.5	11	15	5			0.09
S1206K-SCLCR/L-04K	A1206K-SCLCR/L-04K	12	6	125	14	3.5	11	13	7	CC..0401..	③	0.11
S1607K-SCLCR/L-06-L20	A1607K-SCLCR/L-06-L20	16	7	125	20	4	15	13	8	CC..0602..	④	0.20
S1608K-SCLCR/L-06-L20	A1608K-SCLCR/L-06-L20	16	8	125	20	4.5	15	11	9			0.20
S1608K-SCLCR/L-06-L25	A1608K-SCLCR/L-06-L25	16	8	125	25	4.5	15	11	9			0.20
S1609K-SCLCR/L-06-L25	A1609K-SCLCR/L-06-L25	16	9	125	25	5	15	11	10			0.20
S1612M-SCLPR/L-08	A1612M-SCLPR-08	16	12	150	30	7	15	7	14	CP..0802..	⑤	0.24
S2014M-SCLPR/L-08		20	14	150	30	7.5	18	7	15			0.37
S2016Q-SCLPR-09		20	16	180	20	10.5	18	7	21			CP..0903..

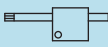
Insert	Spare parts	Screw 	Wrench 
CC..03S1..	①	MS1603B	ETF06
CC..0301..	②	MS1603B	ETF06
CC..0401..	③	MS2004A	ETF06
CC..0602..	④	MS2506A	ETF09
CP..0802..	⑤	MS3008A	ETF09
CP..0903..	⑥	MS4008B	ETF15

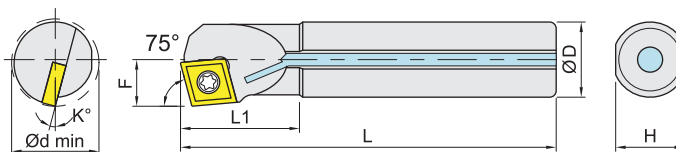
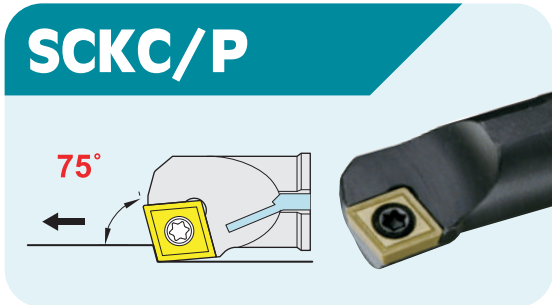

Coolant steel shank (right shown)
中心出水鋼柄 右向示意圖

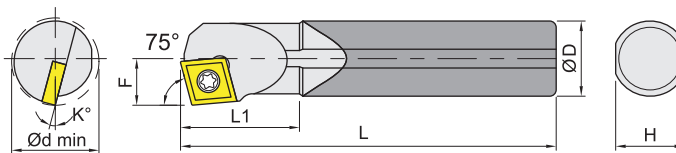

Carbide shank (right shown)
鎢鋼柄 右向示意圖

Steel shank Item code		Dimensions,mm								Insert	Spare parts	Weight Kg
無水孔Non-coolant	水孔Coolant	D	L	L1	F	H	K	dmin				
S08K-SCKCR/L-06	A08K-SCKCR/L-06	8	125	20	5	7	15	10	CC..0602..	①	0.07	
S10K-SCKCR/L-06	A10K-SCKCR/L-06	10	125	22	6	9	13	12			0.09	
S12M-SCKCR/L-06	A12M-SCKCR/L-06	12	150	26	8	11	10	16			0.13	
S16Q-SCKCR/L-06	A16Q-SCKCR/L-06	16	180	32	10	15	7	20			0.28	
S12M-SCKCR/L-09	A12M-SCKCR/L-09	12	150	28	8	11	11	16	CC..09T3..	②	0.13	
S16Q-SCKCR/L-09	A16Q-SCKCR/L-09	16	180	32	10	15	7	20			0.28	
S20R-SCKCR/L-09	A20R-SCKCR/L-09	20	200	40	12.5	18	5	25			③	0.49
S16Q-SCKPR/L-09	A16Q-SCKPR/L-09	16	180	32	10	15	7	20	CP..0903..	④	0.28	

Carbide shank Item code		Dimensions,mm								Insert	Spare parts	Weight Kg
無水孔Non-coolant	水孔Coolant	D	L	L1	F	H	K	dmin				
C08K-SCKCR-06		8	125	20	5	7.2	15	10	CC..0602..	①	0.09	
C12Q-SCKCR-06		12	180	26	8	11.2	10	16			0.29	

Insert	Spare parts	Screw	Wrench
CC..0602..	①	MS2506A	ETF09
CC..09T3..	②	MS4008A	ETF15
CC..09T3..	③	MS4009A	ETF15
CP..0903..	④	MS4008B	ETF15

內徑車刀
BORING BARS

外徑車刀
TOOL HOLDERS

牙刀 & 開槽刀
THREADING & GROOVING

銑刀
MILLING

孔加工
BORING TOOLS COMPONENTS

配件
SPARE PARTS

SCNC/P

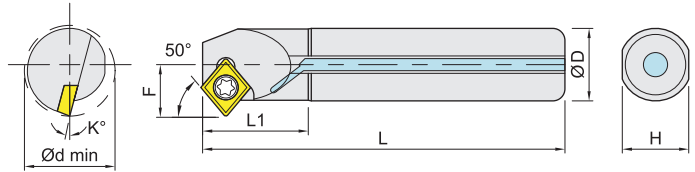
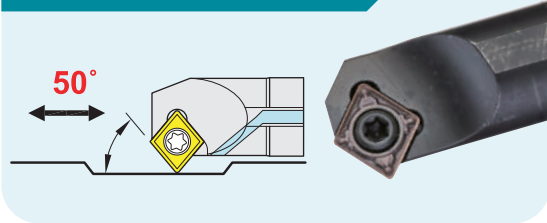

Coolant steel shank (right shown)
中心出水鋼柄 右向示意圖

Steel shank Item code		Dimensions, mm							Insert	Spare parts	Weight Kg
無水孔Non-coolant	水孔Coolant	D	L	L1	F	H	K	dmin			
S12M-SCNCR-06	A12M-SCNCR-06	12	150	26	8.5	11	7	16	CC..0602..	①	0.13
S16Q-SCNPR-09	A16Q-SCNPR-09	16	180	30	10.5	15	7	20	CP..0903..	②	0.28

Insert	Spare parts	Screw	Wrench
CC..0602..	①	MS2506A	ETF09
CP..0903..	②	MS4008B	ETF15

SCZC

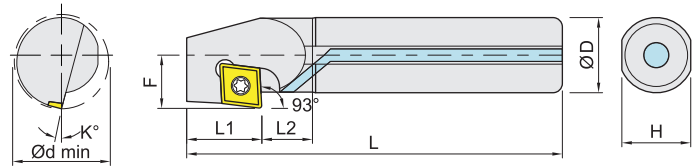
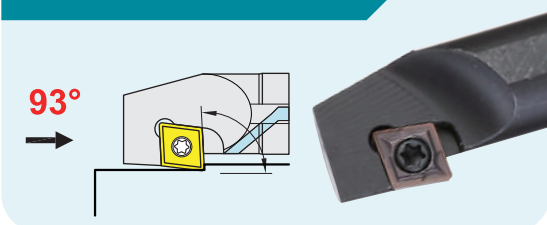

Coolant steel shank (right shown)
中心出水鋼柄 右向示意圖

Steel shank Item code		Dimensions, mm								Insert	Spare parts	Weight Kg
無水孔Non-coolant	水孔Coolant	D	L	L1	L2	F	H	K	dmin			
S08K-SCZCR/L-06	A08K-SCZCR/L-06	8	125	12	18	6	7	15	11	CC..0602..	①	0.07
S10K-SCZCR/L-06	A10K-SCZCR/L-06	10	125	12	18	7.5	9	13	14			0.09
S12M-SCZCR/L-06	A12M-SCZCR/L-06	12	150	12	20	8.5	11	10	16			0.13
S16Q-SCZCR/L-09	A16Q-SCZCR/L-09	16	180	18	22	11.5	15	7	21	CC..09T3..	②	0.28
S20R-SCZCR/L-09	A20R-SCZCR/L-09	20	200	18	22	13.5	18	7	25			0.49
S25R-SCZCR/L-09	A25R-SCZCR/L-09	25	200	18	22	16	23	7	30			③
S40T-SCZCR-12		40	300	22	38	25.5	37	3	50	CC..1204..	④	2.96

Insert	Spare parts	Screw	Wrench
CC..0602..	①	MS2506A	ETF09
CC..09T3..	②	MS4009A	ETF15
CC..09T3..	③	MS4011A	ETF15
CC..1204..	④	MS5011A	ETF20

BORING BARS
內徑車刀

TOOLHOLDERS
外徑車刀

THREADING & GROOVING
牙刀 & 開槽刀

MILLING
銑刀

BORING TOOLS COMPONENTS
孔加工

SPARE PARTS
配件

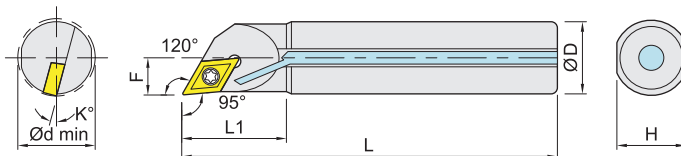
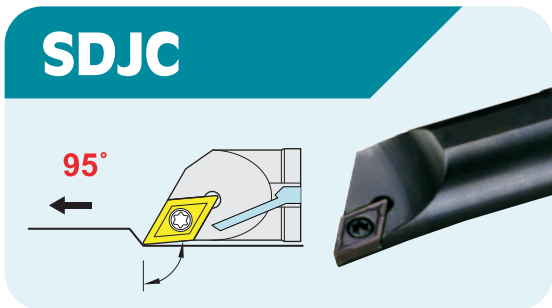

Coolant steel shank (right shown)
中心出水鋼柄 右向示意圖

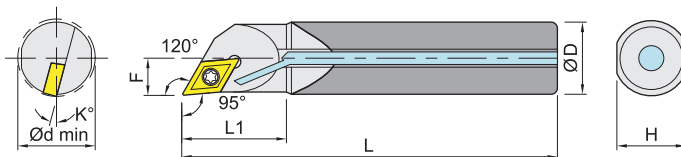

Coolant carbide shank (right shown)
中心出水鎢鋼柄 右向示意圖

Steel shank Item code		Dimensions,mm							Insert	Spare parts	Weight Kg
無水孔Non-coolant	水孔Coolant	D	L	L1	F	H	K	dmin			
S08K-SDJCR/L-07	A08K-SDJCR/L-07	8	125	22	5	7	15	10	DC..0702..	①	0.07
S10K-SDJCR/L-07	A10K-SDJCR/L-07	10	125	25	6	9	13	12			0.09
S12M-SDJCR/L-07	A12M-SDJCR/L-07	12	150	30	7	11	10	14			0.13
S16Q-SDJCR/L-07	A16Q-SDJCR/L-07	16	180	38	9.5	15	7	19			0.28
S1608K-SDJCR/L-07-L20		16	125	20	4.5	15	15	10			0.20
S16Q-SDJCR/L-11	A16Q-SDJCR/L-11	16	180	38	9.5	15	7	19	DC..11T3..	②	0.28
S20R-SDJCR/L-11	A20R-SDJCR/L-11	20	200	42	11.5	18	7	23			0.49
S25R-SDJCR/L-11	A25R-SDJCR/L-11	25	200	45	14	23	5	28			0.77
S25S-SDJCR/L-11	A25S-SDJCR/L-11	25	250	45	14	23	5	28			0.96
S32S-SDJCR/L-11	A32S-SDJCR/L-11	32	250	48	17.5	30	5	35			1.58

Carbide shank Item code		Dimensions,mm							Insert	Spare parts	Weight Kg
無水孔Non-coolant	水孔Coolant	D	L	L1	F	H	K	dmin			
C08K-SDJCR/L-07	E08K-SDJCR-07	8	125	22	5	7.2	15	10	DC..0702..	①	0.09
C10K-SDJCR/L-07	E10K-SDJCR-07	10	125	25	6	9.2	13	12			0.14
C10M-SDJCR/L-07	E10M-SDJCR-07	10	150	25	6	9.2	13	12			0.17
C12M-SDJCR/L-07	E12M-SDJCR-07	12	150	30	7	11.2	10	14			0.24
C12Q-SDJCR/L-07	E12Q-SDJCR-07	12	180	30	7	11.2	10	14			0.29
C16R-SDJCR/L-07	E16R-SDJCR/L-07	16	200	38	9.5	15.2	7	19			0.58
C16R-SDJCR-11		16	200	38	9.5	15.2	7	19	DC..11T3..	②	0.58
C20R-SDJCR-11		20	200	42	11.5	19.2	7	23			0.90
C25S-SDJCR-11		25	250	45	14	24.2	5	28			1.77

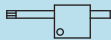
Insert	Spare parts	Screw 	Wrench 
DC..0702..	①	MS2506B	ETF09
DC..11T3..	②	MS4009A	ETF15

內徑車刀
BORING BARS

外徑車刀
TOOL HOLDERS

牙刀 & 開槽刀
THREADING & GROOVING

銑刀
MILLING

孔加工
BORING TOOLS COMPONENTS

配件
SPARE PARTS

SDNC

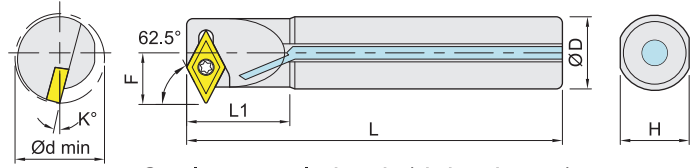
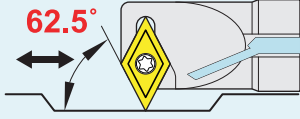

Coolant steel shank (right shown)
中心出水鋼柄 右向示意圖

Steel shank Item code		Dimensions,mm							Insert	Spare parts	Weight Kg
無水孔Non-coolant	水孔Coolant	D	L	L1	F	H	K	dmin			
S12M-SDNCR/L-07	A12M-SDNCR/L-07	12	150	25	9	11	7	16	DC..0702..	①	0.13
S16Q-SDNCR/L-07	A16Q-SDNCR/L-07	16	180	30	11	15	7	20			0.28
S20R-SDNCR/L-11	A20R-SDNCR/L-11	20	200	35	15	18	7	25	DC..11T3..	③	0.49
S25R-SDNCR/L-11	A25R-SDNCR/L-11	25	200	35	17	23	5	32			0.77
S32S-SDNCR/L-11		32	250	40	20.5	30	5	40			1.58

SDZC

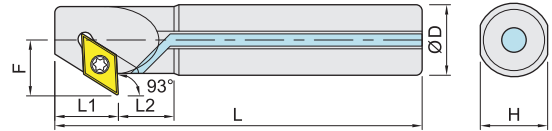
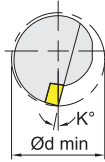
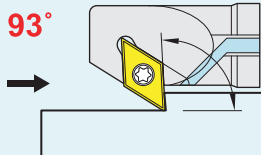

Coolant steel shank (right shown)
中心出水鋼柄 右向示意圖

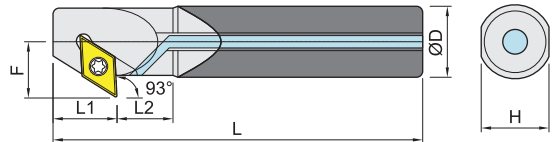
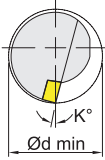

Coolant carbide shank (right shown)
中心出水鎢鋼柄 右向示意圖

Steel shank Item code		Dimensions,mm							Insert	Spare parts	Weight Kg	
無水孔Non-coolant	水孔Coolant	D	L	L1	L2	F	H	K				dmin
S10M-SDZCR/L-07	A10M-SDZCR/L-07	10	150	12	18	8.5	9	13	14	DC..0702..	①	0.09
S12M-SDZCR/L-07	A12M-SDZCR/L-07	12	150	12	20	10.5	11	10	17			0.13
S16Q-SDZCR/L-07	A16Q-SDZCR/L-07	16	180	12	26	12.5	15	7	21			0.28
S16Q-SDZCR/L-11	A16Q-SDZCR/L-11	16	180	18	20	13.5	15	7	22	DC..11T3..	② ③	0.28
S20R-SDZCR/L-11	A20R-SDZCR/L-11	20	200	18	27	15.5	18	7	26			0.49
S25R-SDZCR/L-11	A25R-SDZCR/L-11	25	200	18	32	18	23	5	33			0.77
S32S-SDZCR/L-11	A32S-SDZCR/L-11	32	250	18	42	21.5	30	5	40			1.58

Carbide shank Item code		Dimensions,mm							Insert	Spare parts	Weight Kg	
無水孔Non-coolant	水孔Coolant	D	L	L1	L2	F	H	K				dmin
C10M-SDZCR-07		10	150	12	18	8.5	9.2	13	14	DC..0702..	①	0.17
C12M-SDZCR-07		12	150	12	20	10.5	11.2	10	17			0.24
C16R-SDZCR-07		16	180	12	26	12.5	15.2	7	21			0.58

Insert	Spare parts	Screw	Wrench
DC..0702..	①	MS2506B	ETF09
DC..11T3..	②	MS4009A	ETF15
DC..11T3..	③	MS4011A	ETF15

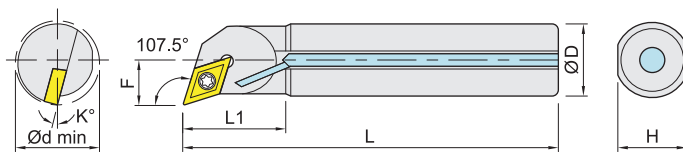
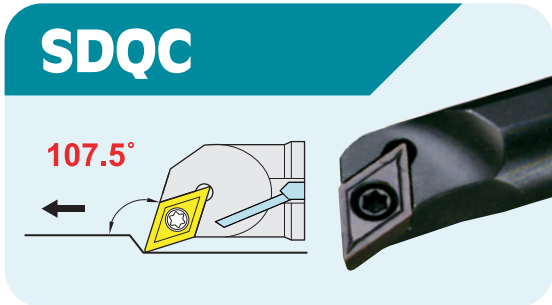

Coolant steel shank (right shown)
中心出水鋼柄 右向示意圖

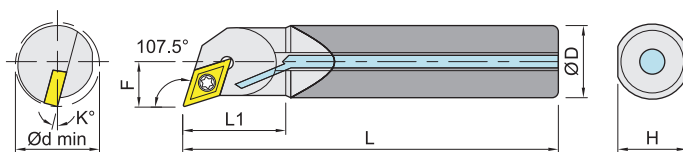

Coolant carbide shank (right shown)
中心出水鎢鋼柄 右向示意圖

Steel shank Item code		Dimensions,mm							Insert	Spare parts	Weight Kg
無水孔Non-coolant	水孔Coolant	D	L	L1	F	H	K	dmin			
S10K-SDQCR/L-07	A10K-SDQCR/L-07	10	125	22	6.5	9	13	13	DC..0702..	①	0.08
S12M-SDQCR/L-07	A12M-SDQCR/L-07	12	150	30	8	11	10	16			0.13
S16Q-SDQCR/L-07	A16Q-SDQCR/L-07	16	180	35	10.25	15	7	20			0.28
S20R-SDQCR/L-07	A20R-SDQCR/L-07	20	200	40	12.5	18	7	25			0.49
S16Q-SDQCR/L-11	A16Q-SDQCR/L-11	16	180	35	10.5	15	7	20	DC..11T3..	②	0.28
S20R-SDQCR/L-11	A20R-SDQCR/L-11	20	200	40	13	18	7	25			0.49
S25R-SDQCR/L-11	A25R-SDQCR/L-11	25	200	45	15.5	23	5	32			0.77
S32S-SDQCR/L-11	A32S-SDQCR/L-11	32	250	48	19.5	30	5	40			1.58
S40T-SDQCR/L-11	A40T-SDQCR/L-11	40	300	55	25	37	3	50			2.96
S50U-SDQCR/L-11	A50U-SDQCR-11	50	350	60	30	47	2	60	5.40		

Carbide shank Item code		Dimensions,mm							Insert	Spare parts	Weight Kg
無水孔Non-coolant	水孔Coolant	D	L	L1	F	H	K	dmin			
C10K-SDQCR/L-07	E10K-SDQCR-07	10	125	22	6	9.2	13	13	DC..0702..	①	0.14
C10M-SDQCR-07	E10M-SDQCR-07	10	150	22	6	9.2	13	13			0.17
C12M-SDQCR/L-07	E12M-SDQCR/L-07	12	150	30	8	11.2	10	16			0.24
C12Q-SDQCR-07	E12Q-SDQCR-07	12	180	30	8	11.2	10	16			0.29
C16R-SDQCR/L-07	E16R-SDQCR/L-07	16	200	35	10.25	15.2	7	20			0.58
C20R-SDQCR-07		20	200	40	12.5	19.2	7	25			0.90
C16R-SDQCR-11	E16R-SDQCR/L-11	16	200	35	10.5	15.2	7	20	DC..11T3..	②	0.58
C20R-SDQCR-11		20	200	40	13	19.2	7	25			0.90
C25S-SDQCR-11		25	250	45	15.5	24.2	5	32			1.77

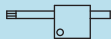
Insert	Spare parts	Screw 	Wrench 
DC..0702..	①	MS2506B	ETF09
DC..11T3..	②	MS4009A	ETF15

內徑車刀
BORING BARS

外徑車刀
TOOL HOLDERS

牙刀 & 開槽刀
THREADING & GROOVING

銑刀
MILLING

孔加工
BORING TOOLS COMPONENTS

配件
SPARE PARTS

SDUC

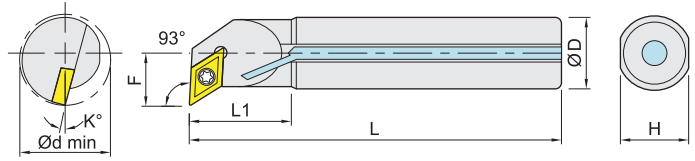
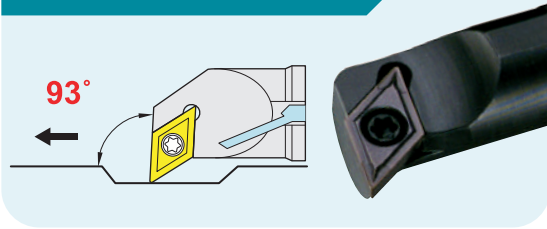

Coolant steel shank (right shown)
中心出水鋼柄 右向示意圖

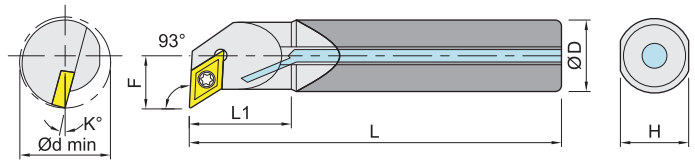

Coolant carbide shank (right shown)
中心出水鎢鋼柄 右向示意圖

Steel shank Item code		Dimensions,mm							Insert	Spare parts	Weight Kg
無水孔Non-coolant	水孔Coolant	D	L	L1	F	H	K	dmin			
S10K-SDUCR/L-07	A10K-SDUCR/L-07	10	125	25	7	9	13	13	DC..0702..	①	0.08
S12M-SDUCR/L-07	A12M-SDUCR/L-07	12	150	30	8.5	11	10	16			0.13
S16Q-SDUCR/L-07	A16Q-SDUCR/L-07	16	180	30	11	15	7	20			0.28
S20R-SDUCR/L-07	A20R-SDUCR/L-07	20	200	40	12.5	18	7	25			0.49
S16Q-SDUCR/L-11	A16Q-SDUCR/L-11	16	180	30	11	15	7	20	DC..11T3..	②	0.28
S20R-SDUCR/L-11	A20R-SDUCR/L-11	20	200	40	13	18	7	25			0.49
S25R-SDUCR/L-11	A25R-SDUCR/L-11	25	200	45	16	23	5	32			0.77
S25S-SDUCR/L-11		25	250	45	16	23	5	32			0.96
S32S-SDUCR/L-11	A32S-SDUCR/L-11	32	250	48	20	30	5	40			1.58
S40T-SDUCR/L-11	A40T-SDUCR/L-11	40	300	55	26	37	3	50	2.96		
S50V-SDUCR/L-11		50	400	60	31	47	3	60	6.16		

Carbide shank Item code		Dimensions,mm							Insert	Spare parts	Weight Kg
無水孔Non-coolant	水孔Coolant	D	L	L1	F	H	K	dmin			
C10K-SDUCR/L-07	E10K-SDUCR/L-07	10	125	25	7	9.2	13	13	DC..0702..	①	0.14
C10M-SDUCR-07	E10M-SDUCR-07	10	150	25	7	9.2	13	13			0.17
C12M-SDUCR/L-07	E12M-SDUCR/L-07	12	150	30	8.5	11.2	10	16			0.24
C12Q-SDUCR-07	E12Q-SDUCR-07	12	180	30	8.5	11.2	10	16			0.29
C16R-SDUCR-07	E16R-SDUCR-07	16	200	30	11	15.2	7	20	0.58		
C16R-SDUCR/L-11	E16R-SDUCR/L-11	16	200	30	11	15.2	7	20	DC..11T3..	②	0.58
C20R-SDUCR/L-11	E20R-SDUCR/L-11	20	200	40	13	19.2	7	25			0.91
C25S-SDUCR-11	E25S-SDUCR-11	25	250	45	16	24.2	5	32			1.77

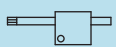
Insert	Spare parts	Screw 	Wrench 
DC..0702..	①	MS2506B	ETF09
DC..11T3..	②	MS4009A	ETF15

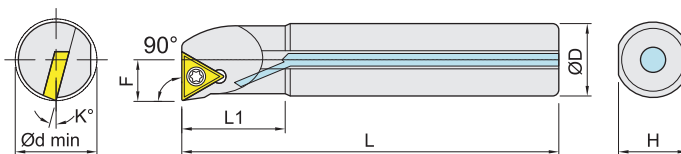
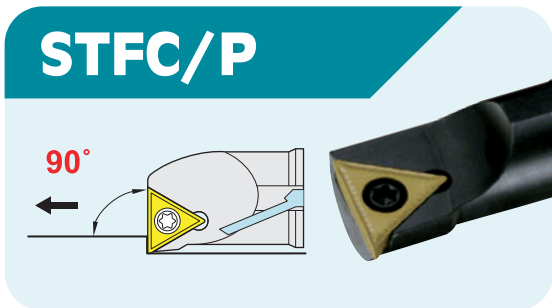

Coolant steel shank (right shown)
中心出水鋼柄 右向示意圖

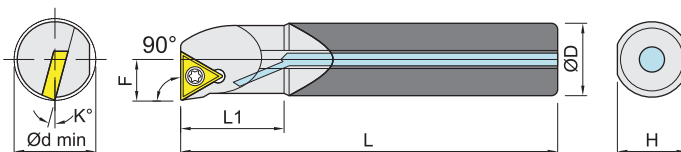

Coolant carbide shank (right shown)
中心出水鎢鋼柄 右向示意圖

Steel shank Item code		Dimensions,mm							Insert	Spare parts	Weight Kg
無水孔Non-coolant	水孔Coolant	D	L	L1	F	H	K	dmin			
S06H-STFCR/L-06	--	6	100	15	3.5	5	15	7	TC..0601..	①	0.02
S08K-STFCR/L-06-D09	A08K-STFCR-06-D09	8	125	20	4.5	7	15	9			TC..0902..
S08K-STFCR/L-09	A08K-STFCR/L-09	8	125	20	5.5	7	15	10	TC..0902..	③	
S10K-STFCR/L-09	A10K-STFCR/L-09	10	125	22	6.25	9	13	12			TC..1102..
S10K-STFCR/L-09-D11	A10K-STFCR/L-09-D11	10	125	22	5.5	9	13	11	TC..1102..	④	
S10K-STFCR/L-11	A10K-STFCR/L-11	10	125	22	6.25	9	13	12			TC..1102..
S12M-STFCR/L-11	A12M-STFCR/L-11	12	150	26	8.25	11	10	16	TC..1102..	④	
S12M-STFCR/L-11-D13	A12M-STFCR/L-11-D13	12	150	26	6.5	11	10	13			TC..1102..
S16Q-STFCR/L-11	A16Q-STFCR/L-11	16	180	32	10	15	7	20	TC..16T3..	⑤	
S16Q-STFCR/L-16	A16Q-STFCR/L-16	16	180	32	10	15	7	20			TC..16T3..
S20R-STFCR/L-16	A20R-STFCR/L-16	20	200	36	13	18	5	25	TC..16T3..	⑤	
S25R-STFCR/L-16	A25R-STFCR/L-16	25	200	40	15	23	5	30			TC..16T3..
S25S-STFCR/L-16	A25S-STFCR/L-16	25	250	40	15	23	5	30	TC..16T3..	⑤	
S32S-STFCR/L-16	A32S-STFCR/L-16	32	250	48	20	30	5	38			TC..16T3..
S32T-STFCR/L-16	A32T-STFCR/L-16	32	300	48	20	30	5	38	TC..16T3..	⑤	
S16Q-STFPR-1603		16	180	32	10	15	7	20			TP..1603..

Carbide shank Item code		Dimensions,mm							Insert	Spare parts	Weight Kg
無水孔Non-coolant	水孔Coolant	D	L	L1	F	H	K	dmin			
C06J-STFCR/L-06	--	6	110	15	3.5	5.7	15	7	TC..0601..	①	0.08
C08K-STFCR/L-09	E08K-STFCR -09	8	125	20	5.5	7.2	15	10	TC..0902..	②	0.11
C10K-STFCR/L-11		10	125	22	6.25	9.2	13	12	TC..1102..	④	0.14
C12M-STFCR/L-11		12	150	26	8.25	11.2	10	16			TC..1102..
C12M-STFCR/L-11-D13		12	150	26	6.5	11.2	10	13	TC..1102..	④	

※鎢鋼柄Ø7以下刀桿僅一面側固(Carbide shank below Ø7 is one weldon flat only)。

Insert	Spare parts	Screw	Wrench
TC..0601..	①	MS2004A	ETF06
TC..0902..	②	MS2205A	ETF07
TC..0902..	③	MS2206A	ETF07
TC..1102..	④	MS2506A	ETF09
TC..16T3..	⑤	MS4011A	ETF15
TP..1603..	⑥	MS4009A	ETF15

內徑車刀
BORING BARS

外徑車刀
TOOL HOLDERS

牙刀 & 開槽刀
THREADING & GROOVING

銑刀
MILLING

孔加工
BORING TOOLS COMPONENTS

配件
SPARE PARTS

STUB/C

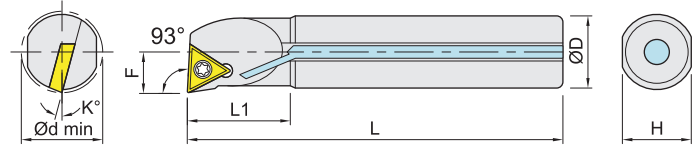
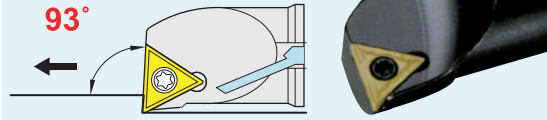

Coolant steel shank (right shown)
中心出水鋼柄 右向示意圖

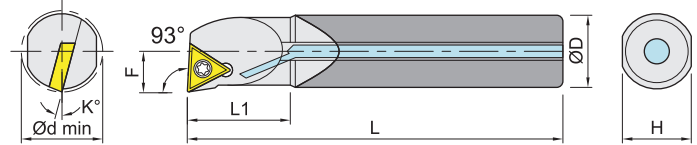

Coolant carbide shank (right shown)
中心出水鎢鋼柄 右向示意圖

BORING BARS
內徑車刀

TOOLHOLDERS
外徑車刀

THREADING & GROOVING
牙刀 & 開槽刀

MILLING
銑刀

BORING TOOLS COMPONENTS
孔加工

SPARE PARTS
配件

Steel shank Item code		Dimensions,mm							Insert	Spare parts	Weight Kg		
無水孔Non-coolant	水孔Coolant	D	L	L1	F	H	K	dmin					
S06H-STUBR/L-06	--	6	100	15	3.5	5	15	7	TB..0601..	①	0.02		
S08K-STUBR/L-06-D09	A08K-STUBR/L-06-D09	8	125	20	4.5	7	15	9			0.07		
S08K-STUCR/L-09	A08K-STUCR/L-09	8	125	20	5.5	7	15	10	TC..0902..	②	0.07		
S10K-STUCR/L-09	A10K-STUCR/L-09	10	125	22	6	9	13	12			0.09		
S10K-STUCR/L-09-D11	A10K-STUCR/L-09-D11	10	125	22	5.5	9	13	11			0.09		
S12M-STUCR-09	A12M-STUCR-09	12	150	26	8	11	10	16			0.13		
S14M-STUCR-09	A14M-STUCR-09	14	150	26	8	13	10	16			0.18		
S10K-STUCR/L-11	A10K-STUCR/L-11	10	125	22	6	9	13	12			TC..1102..	④	0.09
S12M-STUCR/L-11	A12M-STUCR/L-11	12	150	26	8	11	10	16	0.13				
S12M-STUCR/L-11-D13	A12M-STUCR/L-11-D13	12	150	26	6.5	11	10	13	0.13				
S16Q-STUCR/L-11	A16Q-STUCR/L-11	16	180	32	10	15	7	20	0.28				
S16Q-STUCR/L-11-D18	A16Q-STUCR/L-11-D18	16	180	32	9	15	7	18	0.28				
S20R-STUCR/L-11	A20R-STUCR/L-11	20	200	40	13	18	5	25	0.49				
S20R-STUCR/L-16	A20R-STUCR/L-16	20	200	40	13	18	7	25	TC..16T3..	⑤			0.49
S25R-STUCR/L-16	A25R-STUCR/L-16	25	200	40	15	23	5	30					0.77
S32S-STUCR/L-16	A32S-STUCR/L-16	32	250	48	20	30	5	38			1.58		
S32T-STUCR/L-16	A32T-STUCR/L-16	32	300	48	20	30	5	38			1.89		

Carbide shank		Dimensions,mm								Insert	Spare parts	Weight Kg		
無水孔Non-coolant	水孔Coolant	D	L	L1	F	H	K	dmin						
C06J-STUBR/L-06	--	6	110	15	3.5	5.7	15	7	TB..0601..	①	0.05			
C07J-STUBR-06	--	7	110	18	4	6.7	15	8			0.06			
C08K-STUBR/L-06-D09	E08K-STUBR/L-06-D09	8	125	20	4.5	7.2	15	9			0.09			
C08K-STUCR/L-09		8	125	20	5.5	7.2	15	10	TC..0902..	②	0.09			
C10K-STUCR-09		10	125	22	6	9.2	13	12			③	0.14		
C10K-STUCR-09-D11		10	125	22	5.5	9.2	13	11				0.14		
C10M-STUCR-09		10	150	22	6	9.2	13	12				0.17		
C12M-STUCR-09		12	150	26	8	11.2	10	16				0.24		
C12Q-STUCR-09		12	180	26	8	11.2	10	16				0.29		
C14M-STUCR-09		14	150	26	8	13.2	10	16				0.33		
C14R-STUCR-09		14	200	26	8	13.2	10	16				0.44		
C10K-STUCR-11	E10K-STUCR-11	10	125	22	6	9.2	13	12				TC..1102..	④	0.14
C10M-STUCR-11	E10M-STUCR-11	10	150	22	6	9.2	13	12						0.17
C12M-STUCR/L-11	E12M-STUCR-11	12	150	26	8	11.2	10	16	0.24					
C12M-STUCR-11-D13		12	150	26	6.5	11.2	10	13	0.24					
C12Q-STUCR/L-11	E12Q-STUCR-11	12	180	26	8	11.2	10	16	0.29					
C12Q-STUCR-11-D13		12	180	26	6.5	11.2	10	13	0.29					
C16R-STUCR-11	E16R-STUCR-11	16	200	32	10	15.2	7	20	0.58					
C16R-STUCR-11-D18		16	200	32	9	15.2	7	18	0.52					

※ 鎢鋼柄Ø7以下刀桿僅一面側固(Carbide shank below Ø7 is one weldon flat only)。

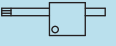
Insert	Spare parts	Screw 	Wrench 
TB..0601..	①	MS2004A	ETF06
TC..0902..	②	MS2205A	ETF07
TC..0902..	③	MS2206A	ETF07
TC..1102..	④	MS2506A	ETF09
TC..16T3..	⑤	MS4011A	ETF15

A10K-STUCR-11

- S=鋼柄(Steel shank)
- A=鋼柄+出水(Steel shank+coolant hole)
- C=鎢鋼柄(Cemented carbide shank with steel head)
- E=鎢鋼柄+出水(Cemented carbide shank with steel head+coolant hole)

內徑車刀
BORING BARS

外徑車刀
TOOL HOLDERS

牙刀 & 開槽刀
THREADING & GROOVING

銑刀
MILLING

孔加工
BORING TOOLS COMPONENTS

配件
SPARE PARTS

STUP

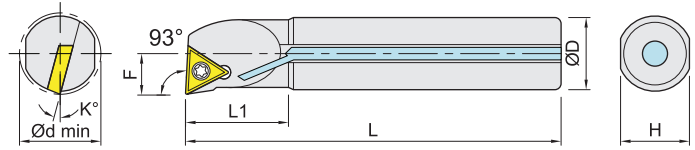
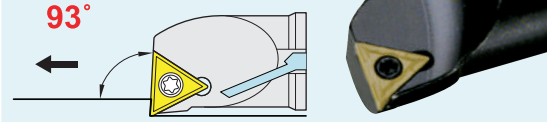

Coolant steel shank (right shown)
中心出水鋼柄 右向示意圖

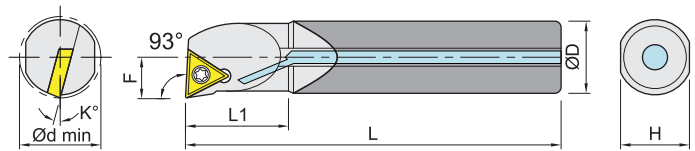

Coolant carbide shank (right shown)
中心出水鎢鋼柄 右向示意圖

Steel shank Item code		Dimensions,mm							Insert	Spare parts	Weight Kg
無水孔Non-coolant	水孔Coolant	D	L	L1	F	H	K	dmin			
S08K-STUPR/L-08	A08K-STUPR/L-08	8	125	20	5.5	7	10	10	TP..0802..	①	0.07
S08K-STUPR/L-08-D09	A08K-STUPR/L-08-D09	8	125	20	4.5	7	10	9			0.07
S10K-STUPR/L-08	A10K-STUPR/L-08	10	125	22	6	9	8	12		②	0.09
S10K-STUPR/L-08-D11	A10K-STUPR/L-08-D11	10	125	22	5.5	9	8	11			0.09
S12M-STUPR/L-08		12	150	26	8	11	8	16		0.13	
S16Q-STUPR/L-08-D18		16	180	32	9	15	7	18		0.28	
S08K-STUPR/L-09	A08K-STUPR/L-09	8	125	20	5.5	7	10	10	TP..0902..	③	0.07
S10K-STUPR/L-09	A10K-STUPR/L-09	10	125	22	6	9	8	12			0.09
S10K-STUPR/L-09-D11	A10K-STUPR/L-09-D11	10	125	22	5.5	9	8	11			0.09
S10K-STUPR/L-11	A10K-STUPR/L-11	10	125	22	6	9	8	12	TP..1103..	④	0.09
S12M-STUPR/L-11	A12M-STUPR/L-11	12	150	26	8	11	8	16			0.13
S12M-STUPR/L-11-D13	A12M-STUPR/L-11-D13	12	150	26	6.5	11	8	13	0.13		
S14Q-STUPR/L-11	A14Q-STUPR/L-11	14	180	26	8	13	7	16	0.22		
S15Q-STUPR/L-11	A15Q-STUPR/L-11	15	180	32	8.5	14	7	17	0.25		
S16Q-STUPR/L-11	A16Q-STUPR/L-11	16	180	32	10	15	7	20	0.28		
S16Q-STUPR/L-11-D18	A16Q-STUPR/L-11-D18	16	180	32	9	15	7	18	0.28		
S18Q-STUPR/L-11	A18Q-STUPR/L-11	18	180	32	10	17	7	20	0.36		
S20R-STUPR/L-11	A20R-STUPR/L-11	20	200	40	13	18	7	25	0.49		
S22R-STUPR-11		22	200	40	13	20	5	25	0.60		
S23R-STUPR-11		23	200	40	13	21	5	26	0.65		
S25R-STUPR/L-11	A25R-STUPR/L-11	25	200	40	15	23	0	30	0.77		
S20R-STUPR/L-1603	A20R-STUPR/L-1603	20	200	40	13	18	4	25	TP..1603..	⑤	0.49
S25R-STUPR/L-1603	A25R-STUPR/L-1603	25	200	40	16	23	0	30			0.77
S32S-STUPR/L-1603	A32S-STUPR/L-1603	32	250	48	20	30	0	38	1.58		
S20R-STUPR/L-16T3	A20R-STUPR/L-16T3	20	200	40	13	18	4	25	TP..16T3..	⑥	0.49
S25R-STUPR/L-16T3	A25R-STUPR/L-16T3	25	200	40	16	23	0	30			0.77
S32S-STUPR/L-16T3	A32S-STUPR/L-16T3	32	250	48	20	30	0	38			1.58
S20R-STUPR/L-1604	A20R-STUPR/L-1604	20	200	40	13	18	4	25	TP..1604..	⑦	0.49
S25R-STUPR/L-1604	A25R-STUPR/L-1604	25	200	40	16	23	0	30			0.77
S32S-STUPR/L-1604	A32S-STUPR/L-1604	32	250	48	20	30	0	38			1.58

BORING BARS
內徑車刀

TOOLHOLDERS
外徑車刀

THREADING & GROOVING
牙刀 & 開槽刀

MILLING
銑刀

BORING TOOLS COMPONENTS
孔加工

SPARE PARTS
配件

Carbide shank Item code		Dimensions,mm							Insert	Spare parts	Weight Kg
無水孔Non-coolant	水孔Coolant	D	L	L1	F	H	K	dmin			
C08K-STUPR/L-08	E08K-STUPR-08	8	125	20	5.5	7.2	10	10	TP..0802..	①	0.09
C08K-STUPR-08-D09	E08K-STUPR-08-D09	8	125	20	4.5	7.2	10	9			0.09
C10K-STUPR-08	E10K-STUPR-08	10	125	22	6	9.2	8	12		②	0.14
C10K-STUPR-08-D11		10	125	22	5.5	9.2	8	11			0.14
C12M-STUPR-08		12	150	26	8	11.2	8	16			0.24
C08K-STUPR/L-09	E08K-STUPR-09	8	125	20	5.5	7.2	10	10	TP..0902..	③	0.09
C10K-STUPR/L-09	E10K-STUPR-09	10	125	22	6	9.2	8	12			0.14
C10M-STUPR-09	E10M-STUPR-09	10	150	22	6	9.2	8	12			0.17
C10M-STUPR-09-D11	E10M-STUPR-09-D11	10	150	22	5.5	9.2	8	11			0.17
C10K-STUPR/L-11	E10K-STUPR/L-11	10	125	22	6	9.2	8	12	TP..1103..	④	0.14
C10M-STUPR-11	E10M-STUPR-11	10	150	22	6	9.2	8	12			0.17
C12M-STUPR/L-11	E12M-STUPR-11	12	150	26	8	11.2	8	16			0.24
C12M-STUPR-11-D13	E12M-STUPR-11-D13	12	150	26	6.5	11.2	8	13			0.24
C12Q-STUPR-11	E12Q-STUPR-11	12	180	26	8	11.2	8	16			0.29
C12Q-STUPR-11-D13	E12Q-STUPR-11-D13	12	180	26	6.5	11.2	8	13			0.29
C14R-STUPR-11	E14R-STUPR-11	14	200	26	8	13.2	7	16			0.44
C16R-STUPR/L-11	E16R-STUPR-11	16	200	32	10	15.2	7	20			0.58
C16R-STUPR-11-D18	E16R-STUPR-11-D18	16	200	32	9	15.2	7	18	0.58		
C20R-STUPR-11	E20R-STUPR-11	20	200	40	13	19.2	7	25	0.90		
C25S-STUPR-11		25	250	40	15	24.2	0	30	1.77		
C20R-STUPL-16T3		20	200	40	13	19.2	4	25	TP..16T3..	⑥	0.90
C20R-STUPR/L-1604		20	200	40	13	19.2	4	25	TP..1604..	⑦	0.90

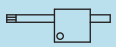
Insert	Spare parts	Screw 	Wrench 
TP..0802..	①	MS2205A	ETF07
TP..0802..	②	MS2206A	ETF07
TP..0902..	③	MS2506A	ETF09
TP..1103..	④	MS3008A	ETF09
TP..1603..	⑤	MS4011A	ETF15
TP..16T3..	⑥	MS4011A	ETF15
TP..1604..	⑦	MS4011A	ETF15

內徑車刀
BORING BARS

外徑車刀
TOOL HOLDERS

牙刀 & 開槽刀
THREADING & GROOVING

銑刀
MILLING

孔加工
BORING TOOLS COMPONENTS

配件
SPARE PARTS

STUB/C

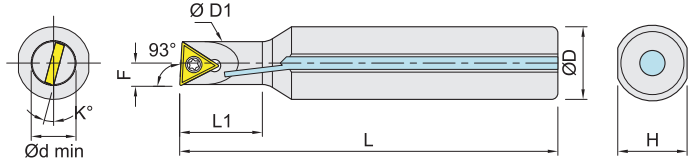
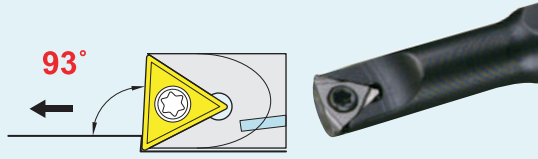

Coolant steel shank (right shown)
中心出水鋼柄 右向示意圖

BORING BARS
內徑車刀

TOOL HOLDERS
外徑車刀

THREADING & GROOVING
牙刀 & 開槽刀

MILLING
銑刀

BORING TOOLS COMPONENTS
孔加工

SPARE PARTS
配件

Steel shank Item code		Dimensions,mm								Insert	Spare parts	Weight Kg
無水孔Non-coolant	水孔Coolant	D	D1	L	L1	F	H	K	dmin			
S0806K-STUBR/L-06-L10		8	6	125	10	3.5	7	12	7	TB..0601..	①	0.07
S0806K-STUBR/L-06-L20	A0806K-STUBR/L-06-L20	8	6	125	20	3.5	7	12	7			0.07
S0806K-STUBR/L-06-L35	A0806K-STUBR/L-06-L35	8	6	125	35	3.5	7	12	7			0.07
S0807K-STUBR/L-06-L20	A0807K-STUBR/L-06-L20	8	7	125	20	4	7	12	8			0.07
S1207K-STUBR/L-06-L20	A1207K-STUBR/L-06-L20	12	7	125	20	4	11	12	8			0.11
S1206K-STUCR-06-L14		12	6	125	14	3.5	11	12	7	TC..0601..	②	0.11
S1207K-STUCR-06-L20		12	7	125	20	4	11	12	8			0.11

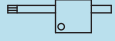
Insert	Spare parts	Screw 	Wrench 
TB..0601..	①	MS2004A	ETF06
TC..0601..	②	MS2004A	ETF06

STWC/P

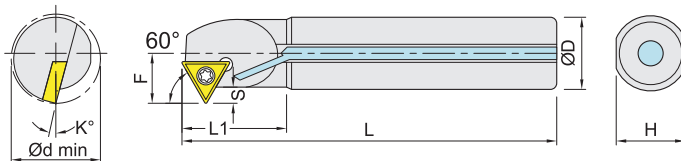
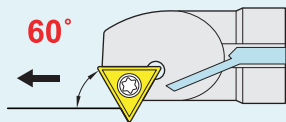

Coolant steel shank (right shown)
中心出水鋼柄 右向示意圖

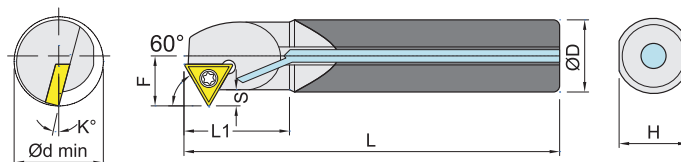

Coolant carbide shank (right shown)
中心出水鎢鋼柄 右向示意圖

Steel shank Item code		Dimensions,mm								Insert	Spare parts	Weight Kg
無水孔Non-coolant	水孔Coolant	D	L	L1	F	S	H	K	dmin			
S0806K-STWBR/L-06-L15	A0806K-STWBR-06-L15	8	125	15	4.5	1.5	7	15	9	TB..0601..	①	0.07
S08K-STWCR/L-09	A08K-STWCR/L-09	8	125	23	6	2	7	15	11	TC..0902..	②	0.07
S10K-STWCR/L-11	A10K-STWCR/L-11	10	125	23	7.5	2.5	9	15	13	TC..1102..	③	0.09
S12M-STWCR/L-11	A12M-STWCR/L-11	12	150	30	8.5	2.5	11	13	16			0.13
S14M-STWCR/L-11		14	150	30	9.5	2.5	13	11	18			0.18
S16Q-STWCR/L-11	A16Q-STWCR/L-11	16	180	35	10.5	2.5	15	10	20			0.28
S20R-STWCR/L-11	A20R-STWCR/L-11	20	200	40	12.5	2.5	18	7	25			0.49
S20R-STWCR/L-16	A20R-STWCR/L-16	20	200	40	14.5	4.5	18	8	26	TC..16T3..	④	0.49
S25R-STWCR/L-16	A25R-STWCR/L-16	25	200	45	17	4.5	23	6	30			0.77
S32S-STWCR/L-16	A32S-STWCR/L-16	32	250	50	20.5	4.5	30	4	40			1.58
S08K-STWPR/L-08	A08K-STWPR/L-08	8	125	20	6	2	7	15	11	TP..0802..	⑤	0.07
S08K-STWPR/L-09	A08K-STWPR/L-09	8	125	23	6	2	7	15	11	TP..0902..	⑥	0.07
S10K-STWPR/L-09	A10K-STWPR/L-09	10	125	23	7.5	2.5	9	15	13	TP..1103..	⑦	0.09
S10K-STWPR/L-11	A10K-STWPR/L-11	10	125	23	7.5	2.5	9	15	13			0.13
S12M-STWPR/L-11	A12M-STWPR/L-11	12	150	30	8.5	2.5	11	13	16			0.18
S14M-STWPR/L-11		14	150	30	9.5	2.5	13	11	18			0.28
S16Q-STWPR/L-11	A16Q-STWPR/L-11	16	180	35	10.5	2.5	15	10	20			0.49
S20R-STWPR/L-11	A20R-STWPR/L-11	20	200	40	12.5	2.5	18	7	25			0.49
S20R-STWPR/L-1603	A20R-STWPR/L-1603	20	200	40	14.5	4.5	18	8	26	TP..1603..	⑧	0.49

Carbide shank Item code		Dimensions,mm								Insert	Spare parts	Weight Kg
無水孔Non-coolant	水孔Coolant	D	L	L1	F	S	H	K	dmin			
C12M-STWCR-11		12	150	30	8.5	2.5	11.2	13	16	TC..1102..	③	0.24
C12Q-STWCR-11		12	180	30	8.5	2.5	11.2	13	16			0.29
C16R-STWCR-11		16	200	35	10.5	2.5	15.2	10	20			0.58
C08K-STWPR-09		8	125	23	6	2	7.2	15	11	TP..0902..	⑥	0.09
C12M-STWPR-11		12	150	30	8.5	2.5	11.2	13	16	TP..1103..	⑦	0.24

Insert	Spare parts	Screw	Wrench
TB..0601..	①	MS2004A	ETF06
TC..0902..	②	MS2205A	ETF07
TC..1102..	③	MS2506A	ETF09
TC..16T3..	④	MS4011A	ETF15
TP..0802..	⑤	MS2205A	ETF07
TP..0902..	⑥	MS2506A	ETF09
TP..1103..	⑦	MS3008A	ETF09
TP..1603..	⑧	MS4011A	ETF15

內徑車刀
BORING BARS

外徑車刀
TOOL HOLDERS

牙刀 & 開槽刀
THREADING & GROOVING

銑刀
MILLING

孔加工
BORING TOOLS COMPONENTS

配件
SPARE PARTS

SVJB/C..CL

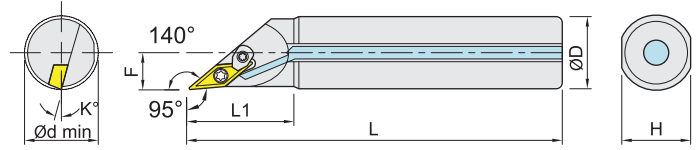
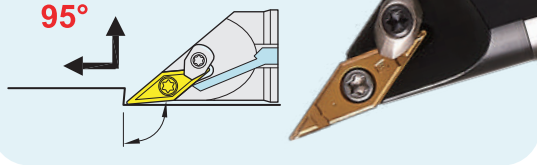

Coolant steel shank+clamp (right shown)

中心出水鋼柄+壓板 右向示意圖

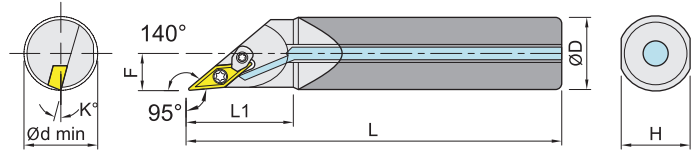

Coolant carbide shank+clamp (right shown)

中心出水鎢鋼柄+壓板 右向示意圖

Steel shank Item code		Dimensions,mm							Insert	Spare parts	Weight Kg
無水孔Non-coolant	水孔Coolant	D	L	L1	F	H	K	dmin			
S16Q-SVJBR/L-11CL	A16Q-SVJBR/L-11CL	16	180	38	9.5	15	7	19	VB..1103..	①	0.28
S20R-SVJBR/L-11CL	A20R-SVJBR/L-11CL	20	200	42	11.5	18	7	23			0.49
S20R-SVJBR/L-16CL	A20R-SVJBR/L-16CL	20	200	42	11.5	18	7	23	VB..1604..	②	0.49
S25R-SVJBR/L-16CL	A25R-SVJBR/L-16CL	25	200	45	14	23	5	28			0.77
S32S-SVJBR/L-16CL	A32S-SVJBR/L-16CL	32	250	50	17.5	30	4	35	VC..1103..	①	1.58
S40T-SVJBR/L-16CL	A40T-SVJBR/L-16CL	40	300	60	21.5	37	2	43			2.96
S16Q-SVJCR/L-11CL	A16Q-SVJCR/L-11CL	16	180	38	9.5	15	7	19	VC..1103..	①	0.28
S20R-SVJCR/L-11CL	A20R-SVJCR/L-11CL	20	200	42	11.5	18	7	23			0.49
S20R-SVJCR/L-16CL	A20R-SVJCR/L-16CL	20	200	42	11.5	18	7	23	VC..1604..	②	0.49
S25R-SVJCR/L-16CL	A25R-SVJCR/L-16CL	25	200	45	14	23	5	28			0.77
S32S-SVJCR/L-16CL	A32S-SVJCR/L-16CL	32	250	50	17.5	30	4	35	VC..1103..	①	1.58
S40T-SVJCR/L-16CL	A40T-SVJCR/L-16CL	40	300	60	21.5	37	2	43			2.96

Carbide shank Item code		Dimensions,mm							Insert	Spare parts	Weight Kg
無水孔Non-coolant	水孔Coolant	D	L	L1	F	H	K	dmin			
C16R-SVJBR/L-11CL	E16R-SVJBR/L-11CL	16	200	38	9.5	15.2	7	19	VB..1103..	①	0.58
C20R-SVJBR/L-11CL	E20R-SVJBR/L-11CL	20	200	42	11.5	19.2	7	23			0.91
C20R-SVJBR/L-16CL	E20R-SVJBR/L-16CL	20	200	42	11.5	19.2	7	23	VB..1604..	②	0.91
C25S-SVJBR/L-16CL	E25S-SVJBR/L-16CL	25	250	45	14	24.2	5	28			1.78
C16R-SVJCR/L-11CL	E16R-SVJCR/L-11CL	16	200	38	9.5	15.2	7	19	VC..1103..	①	0.58
C20R-SVJCR/L-11CL	E20R-SVJCR/L-11CL	20	200	42	11.5	19.2	7	23			0.91
C20R-SVJCR/L-16CL	E20R-SVJCR/L-16CL	20	200	42	11.5	19.2	7	23	VC..1604..	②	0.91
C25S-SVJCR/L-16CL	E25S-SVJCR/L-16CL	25	250	45	14	24.2	5	28			1.78

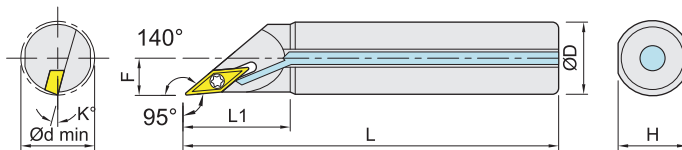
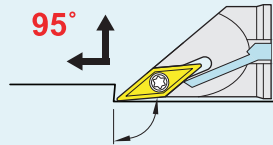

Insert	Spare parts	Screw	Wrench	Clamp	Wrench
VB/VC..1103..	①	MS2506A	ETF09	MC35-5V	ETF15
VB/VC..1604..	②	MS3509B	--	MC35-3V	ETF15

SVJB/C



Coolant steel shank (right shown)
中心出水鋼柄 右向示意圖

Steel shank Item code		Dimensions,mm							Insert	Spare parts	Weight Kg
無水孔Non-coolant	水孔Coolant	D	L	L1	F	H	K	dmin			
S10K-SVJBR/L-11	A10K-SVJBR/L-11	10	125	25	6	9	13	12	VB..1103..	①	0.08
S12M-SVJBR/L-11	A12M-SVJBR/L-11	12	150	30	7	11	10	14			0.13
S16Q-SVJBR/L-11	A16Q-SVJBR/L-11	16	180	38	9.5	15	7	19			0.28
S20R-SVJBR/L-11	A20R-SVJBR/L-11	20	200	42	11.5	18	7	23			0.49
S16Q-SVJBR/L-16	A16Q-SVJBR/L-16	16	180	38	9.5	15	7	19	VB..1604..	②	0.28
S20R-SVJBR/L-16	A20R-SVJBR/L-16	20	200	42	11.5	18	7	23			0.49
S25R-SVJBR/L-16	A25R-SVJBR/L-16	25	200	45	14	23	5	28			0.77
S32S-SVJBR/L-16	A32S-SVJBR/L-16	32	250	50	17.5	30	4	35			1.58
S40T-SVJBR/L-16	A40T-SVJBR/L-16	40	300	60	21.5	37	2	43			2.96
S08K-SVJCR/L-08	A08K-SVJCR/L-08	8	125	22	5	7	15	10	VC..0802..	③	0.07
S10K-SVJCR/L-08	A10K-SVJCR/L-08	10	125	25	6	9	13	12			0.08
S10K-SVJCR/L-11	A10K-SVJCR/L-11	10	125	25	6	9	13	12	VC..1103..	①	0.08
S12M-SVJCR/L-11	A12M-SVJCR/L-11	12	150	30	7	11	10	14			0.13
S16Q-SVJCR/L-11	A16Q-SVJCR/L-11	16	180	38	9.5	15	7	19			0.28
S20R-SVJCR/L-11	A20R-SVJCR/L-11	20	200	42	11.5	18	7	23			0.49
S16Q-SVJCR/L-16	A16Q-SVJCR/L-16	16	180	38	9.5	15	7	19	VC..1604..	②	0.28
S20R-SVJCR/L-16	A20R-SVJCR/L-16	20	200	42	11.5	18	7	23			0.49
S25R-SVJCR/L-16	A25R-SVJCR/L-16	25	200	45	14	23	5	28			0.77
S32S-SVJCR/L-16	A32S-SVJCR/L-16	32	250	50	17.5	30	4	35			1.58
S40T-SVJCR/L-16	A40T-SVJCR/L-16	40	300	60	21.5	37	2	43			2.96

Insert	Spare parts	Screw 	Wrench 
VB/VC..1103..	①	MS2506A	ETF09
VB/VC..1604..	②	MS3509B	ETF15
VC..0802..	③	MS2005A	ETF06

內徑車刀
BORING BARS

外徑車刀
TOOL HOLDERS

牙刀 & 開槽刀
THREADING & GROOVING

銑刀
MILLING

孔加工
BORING TOOLS COMPONENTS

配件
SPARE PARTS

SVJB/C

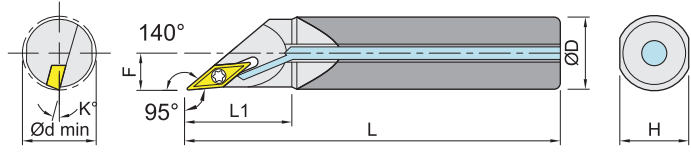
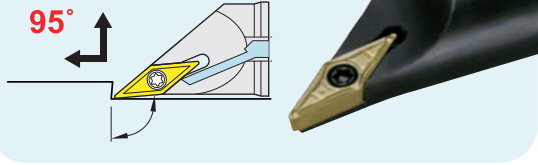

Coolant carbide shank (right shown)
中心出水鎢鋼柄 右向示意圖

Carbide shank Item code		Dimensions,mm							Insert	Spare parts	Weight Kg
無水孔Non-coolant	水孔Coolant	D	L	L1	F	H	K	dmin			
C10K-SVJBR/L-11	E10K-SVJBR-11	10	125	25	6	9.2	13	12	VB..1103..	①	0.14
C12M-SVJBR/L-11	E12M-SVJBR-11	12	150	30	7	11.2	10	14			0.24
C16R-SVJBR/L-11	E16R-SVJBR-11	16	200	38	9.5	15.2	7	19			0.58
C20R-SVJBR/L-11		20	200	42	11.5	19.2	7	23			0.90
C16R-SVJBR-16		16	200	38	9.5	15.2	7	19	VB..1604..	②	0.58
C20R-SVJBR-16		20	200	42	11.5	19.2	7	23			0.90
C25S-SVJBR-16		25	250	45	14	24.2	5	28			1.77
C08K-SVJCR/L-08		8	125	22	5	7.2	15	10	VC..0802..	③	0.09
C10K-SVJCR/L-08		10	125	25	6	9.2	13	12			0.14
C10K-SVJCR/L-11	E10K-SVJCR/L-11	10	125	25	6	9.2	13	12	VC..1103..	①	0.14
C12M-SVJCR/L-11	E12M-SVJCR/L-11	12	150	30	7	11.2	10	14			0.24
C16R-SVJCR/L-11	E16R-SVJCR/L-11	16	200	38	9.5	15.2	7	19			0.58
C20R-SVJCR/L-11	E20R-SVJCR/L-11	20	200	42	11.5	19.2	7	23			0.90
C16R-SVJCR-16		16	200	38	9.5	15.2	7	19	VC..1604..	②	0.58
C20R-SVJCR-16		20	200	42	11.5	19.2	7	23			0.90
C25R-SVJCR-16		25	200	45	14	24.2	5	28			1.77

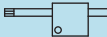
Insert	Spare parts	Screw 	Wrench 
VB/VC..1103..	①	MS2506A	ETF09
VB/VC..1604..	②	MS3509B	ETF15
VC..0802..	③	MS2005A	ETF06

A10K-SVJB/CR-11

- S=鋼柄(Steel shank)
- A=鋼柄+出水(Steel shank+coolant hole)
- C=鎢鋼柄(Cemented carbide shank with steel head)
- E=鎢鋼柄+出水(Cemented carbide shank with steel head+coolant hole)

SVQB/C..CL

117.5°

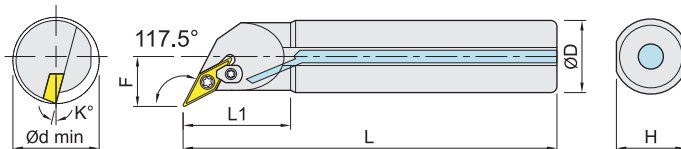
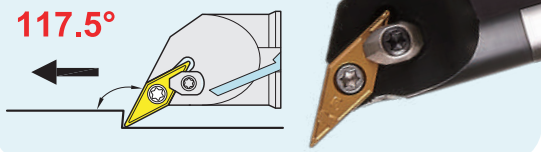

Coolant steel shank+clamp (right shown)
中心出水鋼柄+壓板 右向示意圖

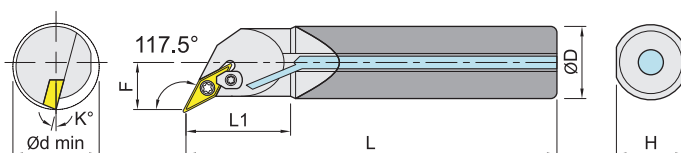

Coolant carbide shank+clamp (right shown)
中心出水鎢鋼柄+壓板 右向示意圖

Steel shank Item code		Dimensions,mm							Insert	Spare parts	Weight Kg
無水孔Non-coolant	水孔Coolant	D	L	L1	F	H	K	dmin			
S12M-SVQBR/L-11CL		12	150	28	9	11	10	16	VB..1103..	①	0.13
S20R-SVQBR/L-16CL	A20R-SVQBR/L-16CL	20	200	40	13.5	18	5	27	VB..1604..	②	0.49
S25R-SVQBR/L-16CL	A25R-SVQBR/L-16CL	25	200	45	16	23	5	32			0.77
S25S-SVQBR/L-16CL	A25S-SVQBR/L-16CL	25	250	45	16	23	5	32			0.96
S32S-SVQBR/L-16CL	A32S-SVQBR/L-16CL	32	250	48	20	30	5	40		③	1.58
S40T-SVQBR/L-16CL	A40T-SVQBR/L-16CL	40	300	60	25.5	37	5	50			2.96
S20R-SVQCR/L-16CL	A20R-SVQCR/L-16CL	20	200	40	13.5	18	5	27	VC..1604..	②	0.49
S25R-SVQCR/L-16CL	A25R-SVQCR/L-16CL	25	200	45	16	23	5	32			0.77
S25S-SVQCR/L-16CL	A25S-SVQCR/L-16CL	25	250	45	16	23	5	32			0.96
S32S-SVQCR/L-16CL	A32S-SVQCR/L-16CL	32	250	48	20	30	5	40		③	1.58
S40T-SVQCR/L-16CL	A40T-SVQCR/L-16CL	40	300	60	25.5	37	5	50			2.96

Carbide shank Item code		Dimensions,mm							Insert	Spare parts	Weight Kg
無水孔Non-coolant	水孔Coolant	D	L	L1	F	H	K	dmin			
C20R-SVQBR/L-16CL	E20R-SVQBR/L-16CL	20	200	40	13.5	19.2	5	27	VB..1604..	②	0.92
C25S-SVQBR/L-16CL	E25S-SVQBR/L-16CL	25	250	45	16	24.2	5	32			1.78
C20R-SVQCR/L-16CL	E20R-SVQCR/L-16CL	20	200	40	13.5	19.2	5	27	VC..1604..	②	0.92
C25S-SVQCR/L-16CL	E25S-SVQCR/L-16CL	25	250	45	16	24.2	5	32			1.78

Insert	Spare parts	Shim	Screw	Wrench	Screw	Wrench	Clamp	Wrench
VB/VC..1103..	①	--	--	--	MS2506A	ETF09	MC35-3V	ETF15
VB/VC..1604..	②	--	--	--	MS3509B	--	MC35-3V	ETF15
VB/VC..1604..	③	VSS322	MDS05035S	PL35	MS3512B	--	MC35-3V	ETF15

內徑車刀
BORING BARS

外徑車刀
TOOL HOLDERS

牙刀 & 開槽刀
THREADING & GROOVING

銑刀
MILLING

孔加工
BORING TOOLS COMPONENTS

配件
SPARE PARTS

SVQB/C

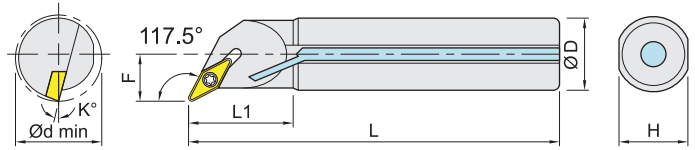
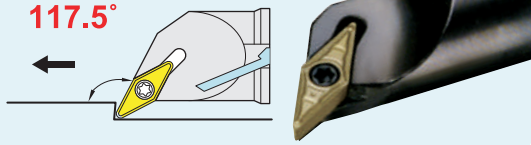

Coolant steel shank (right shown)
中心出水鋼柄 右向示意圖

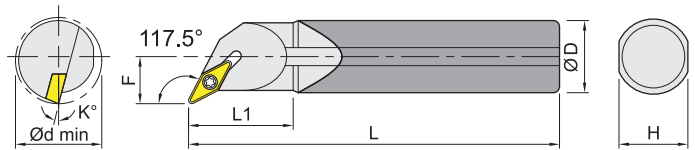

Carbide shank (right shown)
鎢鋼柄 右向示意圖

BORING BARS
內徑車刀

TOOLHOLDERS
外徑車刀

THREADING & GROOVING
牙刀 & 開槽刀





MILLING
銑刀

BORING TOOLS COMPONENTS
孔加工

SPARE PARTS
配件

Steel shank Item code		Dimensions,mm							Insert	Spare parts	Weight Kg
無水孔Non-coolant	水孔Coolant	D	L	L1	F	H	K	dmin			
S12M-SVQBR/L-11	A12M-SVQBR/L-11	12	150	28	9	11	10	16	VB..1103..	①	0.13
S16Q-SVQBR/L-11	A16Q-SVQBR/L-11	16	180	35	11	15	7	20			0.28
S20R-SVQBR/L-11	A20R-SVQBR/L-11	20	200	40	13	18	7	25			0.49
S20R-SVQBR/L-16	A20R-SVQBR/L-16	20	200	40	13.5	18	5	27	VB..1604..	②	0.49
S25R-SVQBR/L-16	A25R-SVQBR/L-16	25	200	45	16	23	5	32			0.77
S25S-SVQBR/L-16	A25S-SVQBR/L-16	25	250	45	16	23	5	32			0.96
S32S-SVQBR/L-16	A32S-SVQBR/L-16	32	250	48	20	30	5	40	VB..1604..	③	1.58
S32V-SVQBR/L-16		32	400	48	20	30	5	40			2.53
S40T-SVQBR/L-16		40	300	60	25.5	37	5	50			2.96
S40V-SVQBR/L-16		40	400	60	25.5	37	5	50			3.95
S12M-SVQCR/L-11	A12M-SVQCR/L-11	12	150	28	9	11	10	16	VC..1103..	①	0.13
S16Q-SVQCR/L-11	A16Q-SVQCR/L-11	16	180	35	11	15	7	20			0.28
S20R-SVQCR/L-11	A20R-SVQCR/L-11	20	200	40	13	18	7	25			0.49
S20R-SVQCR/L-16	A20R-SVQCR/L-16	20	200	40	13.5	18	5	27	VC..1604..	②	0.49
S25R-SVQCR/L-16	A25R-SVQCR/L-16	25	200	45	16	23	5	32			0.77
S25S-SVQCR/L-16	A25S-SVQCR/L-16	25	250	45	16	23	5	32			0.96
S32S-SVQCR/L-16	A32S-SVQCR/L-16	32	250	48	20	30	5	40	VC..1604..	③	1.58
S40T-SVQCR/L-16		40	300	60	25.5	37	5	50			2.96
S40V-SVQCR/L-16		40	400	60	25.5	37	5	50			3.95

Carbide shank		Dimensions,mm							Insert	Spare parts	Weight Kg
無水孔Non-coolant	水孔Coolant	D	L	L1	F	H	K	dmin			
C12M-SVQBR-11		12	150	28	9	11.2	10	16	VB..1103..	①	0.24
C16R-SVQBR-11		16	200	35	11	15.2	7	20			0.58
C20R-SVQBR-11		20	200	40	13	19.2	7	25			0.90
C20R-SVQBR-16		20	200	40	13.5	19.2	5	27	VB..1604..	②	0.90
C25S-SVQBR-16		25	250	45	16	24.2	5	32			1.77
C12M-SVQCR/L-11		12	150	28	9	11.2	10	16	VC..1103..	①	0.24
C16R-SVQCR/L-11		16	200	35	11	15.2	7	20			0.58
C20R-SVQCR/L-11		20	200	40	13	19.2	7	25			0.90
C20R-SVQCR-16		20	200	40	13.5	19.2	5	27	VC..1604..	②	0.90
C25S-SVQCR-16		25	250	45	16	24.2	5	32			1.77

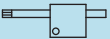
Insert	Spare parts	Shim 	Screw 	Wrench 	Screw 	Wrench 
VB/VC..1103..	①	--	--	--	MS2506A	ETF09
VB/VC..1604..	②	--	--	--	MS3509B	ETF15
VB/VC..1604..	③	VSS322	MDS05035S	PL35	MS3512B	ETF15

A25K-SVQBR-16

S=鋼柄(Steel shank)
 A=鋼柄+出水(Steel shank+coolant hole)
 C=鎢鋼柄(Cemented carbide shank with steel head)
 E=鎢鋼柄+出水(Cemented carbide shank with steel head+coolant hole)

內徑車刀
BORING BARS

外徑車刀
TOOL HOLDERS

牙刀 & 開槽刀
THREADING & GROOVING

銑刀
MILLING

孔加工
BORING TOOLS COMPONENTS

配件
SPARE PARTS

SVUB/C..CL

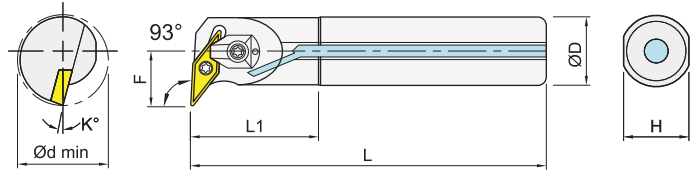
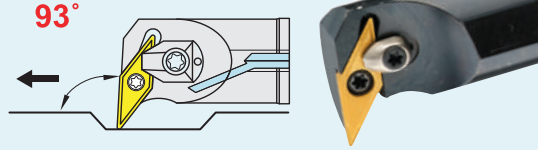

Coolant steel shank+clamp (right shown)
中心出水鋼柄+壓板 右向示意圖

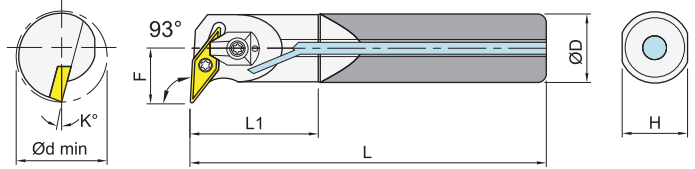

Carbide shank+clamp (right shown)
鎢鋼柄+壓板 右向示意圖

Steel shank Item code		Dimensions,mm							Insert	Spare parts	Weight Kg
無水孔Non-coolant	水孔Coolant	D	L	L1	F	H	K	dmin			
S16Q-SVUBR/L-11CL	A16Q-SVUBR/L-11CL	16	180	30	13	15	7	22	VB..1103..	①	0.28
S20R-SVUBR/L-11CL	A20R-SVUBR/L-11CL	20	200	40	15	18	7	27			0.49
S20R-SVUBR/L-16CL	A20R-SVUBR/L-16CL	20	200	40	19.5	18	5	32		VB..1604..	②
S25R-SVUBR-16CL		25	200	45	18	23	5	32	0.77		
S32S-SVUBR/L-16CL	A32S-SVUBR/L-16CL	32	250	50	22	30	5	40	③		1.58
S40T-SVUBR-16CL		40	300	55	27	37	5	50		2.96	
S16Q-SVUCR/L-11CL	A16Q-SVUCR/L-11CL	16	180	30	13	15	7	22	VC..1103..	①	0.28
S20R-SVUCR/L-11CL	A20R-SVUCR/L-11CL	20	200	40	15	18	7	27			0.49
S20R-SVUCR/L-16CL	A20R-SVUCR/L-16CL	20	200	40	19.5	18	5	32	VC..1604..	②	0.49
S25R-SVUCR/L-16CL	A25R-SVUCR -16CL	25	200	45	18	23	5	32			0.77
S32S-SVUCR-16CL		32	250	50	22	30	5	40	VC..1604..	③	1.58
S40T-SVUCR-16CL	A40T-SVUCR -16CL	40	300	55	27	37	5	50			2.96
S40U-SVUCR-16CL		40	350	55	27	37	5	50			3.45

Carbide shank Item code		Dimensions,mm							Insert	Spare parts	Weight Kg
無水孔Non-coolant	水孔Coolant	D	L	L1	F	H	K	dmin			
C16R-SVUBR-11CL		16	200	30	13	15.2	7	22	VB..1103..	①	0.58
C20R-SVUBR-11CL		20	200	40	15	19.2	7	27			0.91
C20R-SVUBR-16CL		20	200	40	19.5	19.2	5	32		VB..1604..	②
C25S-SVUBR-16CL		25	250	45	18	24.2	5	32	1.77		
C16R-SVUCR/L-11CL	E16R-SVUCR-11CL	16	200	30	13	15.2	7	22	VC..1103..	①	0.58
C20R-SVUCR/L-11CL		20	200	40	15	19.2	7	27			0.91
C20R-SVUCR-16CL	E20R-SVUCR-16CL	20	200	40	19.5	19.2	5	32	VC..1604..	②	0.91
C25S-SVUCR-16CL		25	250	45	18	24.2	5	32			1.77

Insert	Spare parts	Shim	Screw	Wrench	Screw	Wrench	Clamp	Wrench
VB/VC..1103..	①	--	--	--	MS2506A	ETF09	MC35-3V	ETF15
VB/VC..1604..	②	--	--	--	MS3509B	--	MC35-3V	ETF15
VB/VC..1604..	③	VSS322	MDS05035S	PL35	MS3512B	--	MC35-3V	ETF15

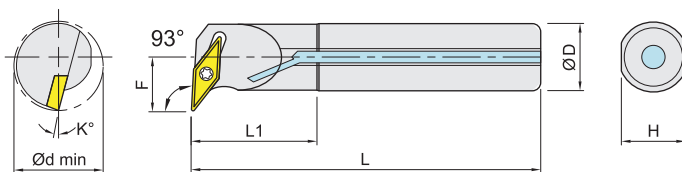
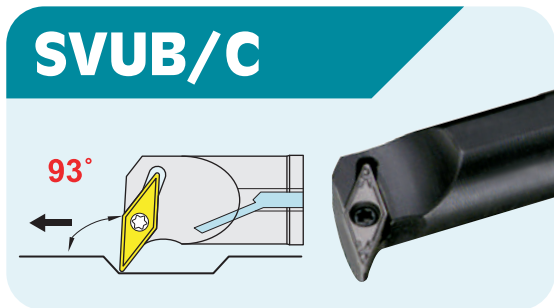

Coolant steel shank (right shown)
中心出水鋼柄 右向示意圖

Steel shank Item code		Dimensions,mm							Insert	Spare parts	Weight Kg	
無水孔Non-coolant	水孔Coolant	D	L	L1	F	H	K	dmin				
S16Q-SVUBR/L-11	A16Q-SVUBR/L-11	16	180	30	13	15	7	22	VB..1103..	①	0.28	
S20R-SVUBR/L-11	A20R-SVUBR/L-11	20	200	40	15	18	7	27			0.49	
S25R-SVUBR/L-16	A25R-SVUBR/L-16	25	200	45	18	23	5	32		VB..1604..	②	0.77
S25S-SVUBR/L-16	A25S-SVUBR/L-16	25	250	45	18	23	5	32				0.96
S32S-SVUBR/L-16	A32S-SVUBR/L-16	32	250	50	22	30	5	40			③	1.58
S40T-SVUBR/L-16	A40T-SVUBR/L-16	40	300	55	27	37	5	50				2.96
S40U-SVUBR/L-16		40	350	55	27	37	5	50				3.45
S40V-SVUBR/L-16		40	400	55	27	37	5	50				3.95
S12M-SVUCR/L-08	A12M-SVUCR/L-08	12	150	26	9.5	11	10	16	VC..0802..	④	0.13	
S1612M-SVUCR/L-08	A1612M-SVUCR/L-08	16	150	31	9.5	15	10	16			0.24	
S16Q-SVUCR/L-11	A16Q-SVUCR/L-11	16	180	30	13	15	7	22	VC..1103..	①	0.28	
S20R-SVUCR/L-11	A20R-SVUCR/L-11	20	200	40	15	18	7	27			0.49	
S25R-SVUCR/L-16	A25R-SVUCR/L-16	25	200	45	18	23	5	32	VC..1604..	②	0.77	
S25S-SVUCR/L-16	A25S-SVUCR/L-16	25	250	45	18	23	5	32			0.96	
S32S-SVUCR/L-16	A32S-SVUCR/L-16	32	250	50	22	30	5	40	VC..1604..	③	1.58	
S40T-SVUCR/L-16	A40T-SVUCR/L-16	40	300	55	27	37	5	50			2.96	
S40U-SVUCR/L-16	A40U-SVUCR/L-16	40	350	55	27	37	5	50			3.45	
S40V-SVUCR/L-16	A40V-SVUCR/L-16	40	400	55	27	37	5	50			3.95	

Insert	Spare parts	Shim	Screw	Wrench	Screw	Wrench
VB/VC..1103..	①	--	--	--	MS2506A	ETF09
VB/VC..1604..	②	--	--	--	MS3509B	ETF15
VB/VC..1604..	③	VSS322	MDS05035S	PL35	MS3512B	ETF15
VC..0802..	④	--	--	--	MS2005A	ETF06

內徑車刀
BORING BARS

外徑車刀
TOOL HOLDERS

牙刀 & 開槽刀
THREADING & GROOVING

銑刀
MILLING

孔加工
BORING TOOLS COMPONENTS

配件
SPARE PARTS

SVVB/C..CL

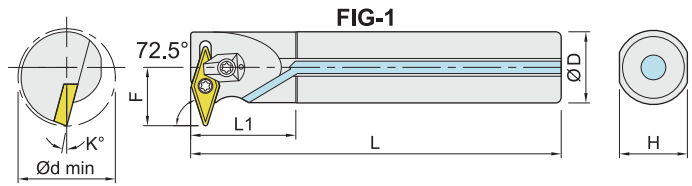
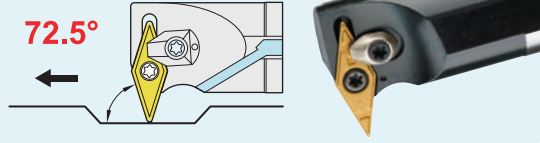

FIG-1
Coolant steel shank+clamp (right shown)
中心出水鋼柄+壓板 右向示意圖

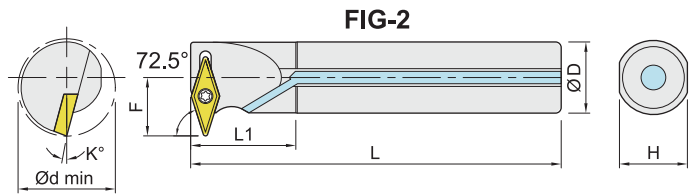
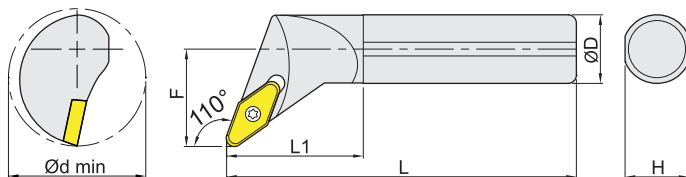
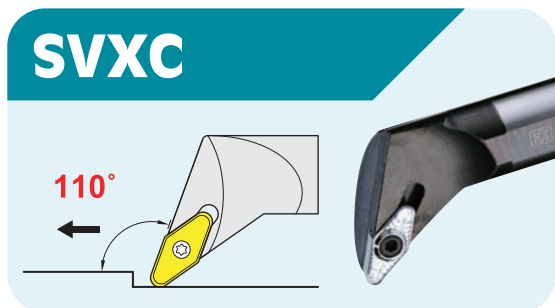

FIG-2
Coolant steel shank (right shown)
中心出水鋼柄 右向示意圖

FIG-1 Steel shank Item code		Dimensions,mm							Insert	Spare parts	Weight Kg
無水孔Non-coolant	水孔Coolant	D	L	L1	F	H	K	dmin			
S16Q-SVVB/L-11CL	A16Q-SVVB/L-11CL	16	180	35	13	15	6	25	VB..1103..	①	0.28
S20R-SVVB/L-11CL	A20R-SVVB/L-11CL	20	200	38	16	18	5	32			0.49
S25R-SVVB/L-16CL	A25R-SVVB/L-16CL	25	200	45	20.5	23	5	34	VB..1604..	②	0.77
S25S-SVVB/L-16CL	A25S-SVVB/L-16CL	25	250	45	20.5	23	5	34			0.96
S32S-SVVB/L-16CL	A32S-SVVB/L-16CL	32	250	50	25.5	30	5	42			③
S16Q-SVVC/L-11CL	A16Q-SVVC/L-11CL	16	180	35	13	15	6	25	VC..1103..	①	0.28
S20R-SVVC/L-11CL	A20R-SVVC/L-11CL	20	200	38	16	18	5	32			0.49
S25R-SVVC/L-16CL	A25R-SVVC/L-16CL	25	200	45	20.5	23	5	34	VC..1604..	②	0.77
S25S-SVVC/L-16CL	A25S-SVVC/L-16CL	25	250	45	20.5	23	5	34			0.96
S32S-SVVC/L-16CL	A32S-SVVC/L-16CL	32	250	50	25.5	30	5	42			③

FIG-2 Steel shank Item code		Dimensions,mm							Insert	Spare parts	Weight Kg
無水孔Non-coolant	水孔Coolant	D	L	L1	F	H	K	dmin			
S25R-SVVB/L-16	A25R-SVVB/L-16	25	200	45	20.5	23	5	34	VB..1604..	④	0.77
S25S-SVVB/L-16		25	250	45	20.5	23	5	34			0.96
S32S-SVVB/L-16		32	250	50	25.5	30	5	42			⑤
S25S-SVVC/L-16		25	250	45	20.5	23	5	34	VC..1604..	④	0.96
S32S-SVVC/L-16		32	250	50	25.5	30	5	42			⑤

Insert	Spare parts	Shim	Screw	Wrench	Screw	Wrench	Clamp	Wrench
VB/VC..1103..	①	--	--	--	MS2506A	ETF09	MC35-3V	ETF15
VB/VC..1604..	②	--	--	--	MS3509B	--	MC35-3V	ETF15
VB/VC..1604..	③	VSS322	MDS05035S	PL35	MS3512B	--	MC35-3V	ETF15
VB/VC..1604..	④	--	--	--	MS3509B	ETF15	--	--
VB/VC..1604..	⑤	VSS322	MDS05035S	PL35	MS3512B	ETF15	--	--



Steel shank (right shown)
鋼柄 右向示意圖

Steel shank Item code		Dimensions,mm						Insert	Spare parts	Weight Kg
無水孔Non-coolant	水孔Coolant	D	L	L1	F	H	dmin			
S25N-SVXCR-22-A125-D71		25	160	50	35.5	23	50	VC..2205..	①	0.62

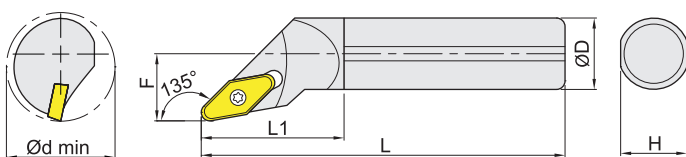
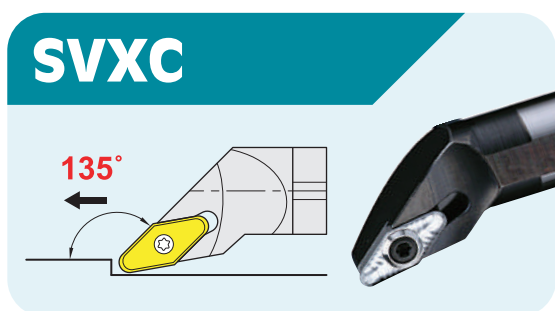

Steel shank (right shown)
鋼柄 右向示意圖

Steel shank Item code		Dimensions,mm						Insert	Spare parts	Weight Kg
無水孔Non-coolant	水孔Coolant	D	L	L1	F	H	dmin			
S25N-SVXCR-22-A100-D47		25	160	50	23.5	23	38	VC..2205..	①	0.62

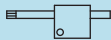
Insert	Spare parts	Screw 	Wrench 
VC..2205..	①	MS5011A	ETF20

內徑車刀
BORING BARS

外徑車刀
TOOL HOLDERS

牙刀 & 開槽刀
THREADING & GROOVING

銑刀
MILLING

孔加工
BORING TOOLS COMPONENTS

配件
SPARE PARTS

SWLC

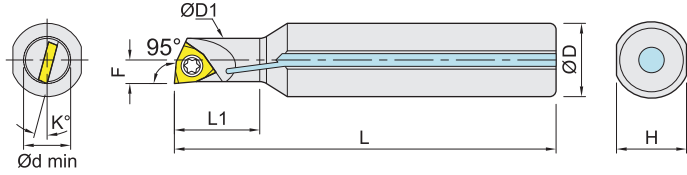
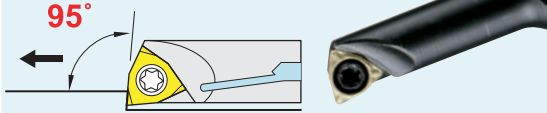

Coolant steel shank (right shown)
中心出水鋼柄 右向示意圖

Steel shank Item code		Dimensions,mm								Insert	Spare parts	Weight Kg
無水孔Non-coolant	水孔Coolant	D	D1	L	L1	F	H	K	dmin			
S0805K-SWLCR-02-L15	A0805K-SWLCR-02-L15	8	5	125	15	3.0	7	12	6	WC..0201..	①	0.05
S0805K-SWLCR-02-L18	A0805K-SWLCR-02-L18	8	5	125	18	3.0	7	12	6			0.05
S1005K-SWLCR-02-L15	A1005K-SWLCR-02-L15	10	5	125	15	3.0	9	12	6			0.08
S1006K-SWLCR-02-L15		10	6	125	15	3.5	9	12	7			0.08

Insert	Spare parts	Screw	Wrench
WC..0201..	①	MS2003A	ETF06

SWUB

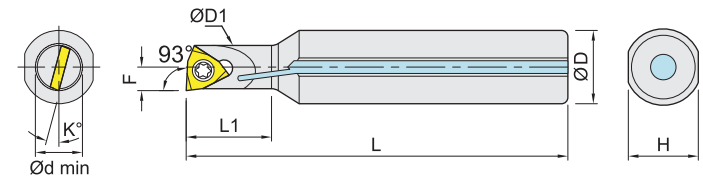
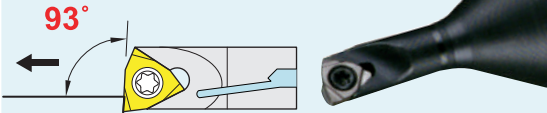

Coolant steel shank (right shown)
中心出水鋼柄 右向示意圖

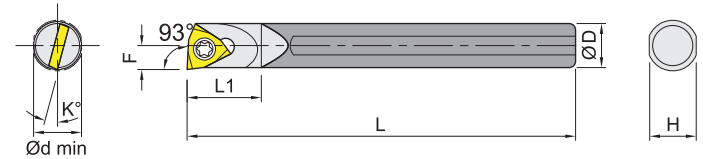

Carbide shank (right shown)
鎢鋼柄 右向示意圖

Steel shank Item code		Dimensions,mm								Insert	Spare parts	Weight Kg	
無水孔Non-coolant	水孔Coolant	D	D1	L	L1	F	H	K	dmin				
S1005K-SWUBR/L-06-L15	A1005K-SWUBR/L-06-L15	10	5	125	15	3.0	9	12	6	WB..0601..	①	0.08	
S1006K-SWUBR/L-06-L18	A1006K-SWUBR/L-06-L18	10	6	125	18	3.5	9	12	7			0.08	
S1007K-SWUBR/L-06-L20	A1007K-SWUBR/L-06-L20	10	7	125	20	4.0	9	12	8	WB..0601..	②	0.08	
S1205K-SWUBR/L-06-L15	A1205K-SWUBR/L-06-L15	12	5	125	15	3.0	11	12	6			①	0.11
S1605K-SWUBR/L-06-L15	A1605K-SWUBR/L-06-L15	16	5	125	15	3.0	15	12	6			①	0.20

Carbide shank Item code		Dimensions,mm								Insert	Spare parts	Weight Kg
無水孔Non-coolant	水孔Coolant	D	D1	L	L1	F	H	K	dmin			
C05H-SWUBR/L-06	--	5	--	100	15	3.0	4.7	12	6	WB..0601..	①	0.03
C06J-SWUBR/L-06	--	6	--	110	15	3.5	5.7	12	7			0.05
C07J-SWUBR-06	--	7	--	110	18	4.0	6.7	12	8			②

※鎢鋼柄Ø7以下刀桿僅一面側固(Carbide shank below Ø7 is one weldon flat only)。

Insert	Spare parts	Screw	Wrench
WB..0601..	①	MS2003A	ETF06
WB..0601..	②	MS2004A	ETF06



SHAN GIN

内 徑 車 刀 套 筒

SLEEVES FOR BORING BARS



FIG-1

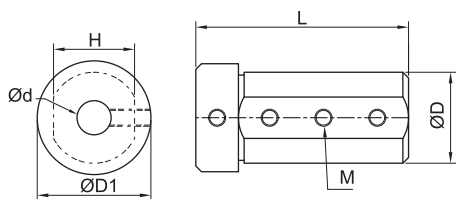

FIG-2

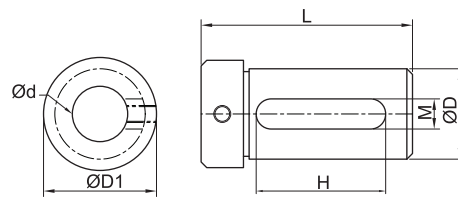
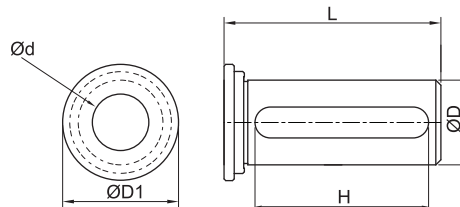

FIG-3



無水孔 Non-coolant	SHAPE	Dimensions,mm					Weight (kg)
		d	D	L	H	M	
NC1603	FIG-1	3	16	62	14.5	M4	0.11
NC1604	FIG-1	4	16	62	14.5	M5	0.10
NC1605	FIG-1	5	16	62	14.5	M5	0.08
NC1606	FIG-1	6	16	62	14.5	M5	0.08
NC1608	FIG-1	8	16	62	14	M5	0.07
NC1610	FIG-1	10	16	62	14.2	M5	0.06
NC1612	FIG-2	12	16	62	50	11	0.06
NC2004	FIG-1	4	20	67	17.5	M5	0.17
NC2005	FIG-1	5	20	67	17.5	M5	0.17
NC2006	FIG-1	6	20	67	17.5	M6	0.16
NC2007	FIG-1	7	20	67	17.5	M6	0.15
NC2008	FIG-1	8	20	67	17.5	M6	0.14
NC2010	FIG-1	10	20	67	17.5	M6	0.13
NC2012	FIG-1	12	20	67	17.5	M6	0.12
NC2014	FIG-2	14	20	67	53	13	0.09
NC2015	FIG-2	15	20	67	53	13	0.08
NC2016	FIG-2	16	20	67	53	13	0.07
NC20S06	FIG-1	6	20	52	18.5	M6	0.13
NC20S08	FIG-1	8	20	52	18.5	M6	0.12
NC20S10	FIG-1	10	20	52	18.5	M6	0.11
NC20S12	FIG-1	12	20	52	18.5	M6	0.10
NC20S16	FIG-2	16	20	52	39	11	0.06

無水孔 Non-coolant	SHAPE	Dimensions,mm					Weight (kg)
		d	D	L	H	M	
NC2514	FIG-3	14	25	64	51	12	0.20
NC2515	FIG-3	15	25	64	51	12	0.19
NC2516	FIG-3	16	25	64	51	12	0.18
NC2517	FIG-3	17	25	64	51	12	0.17
NC2518	FIG-3	18	25	64	51	12	0.16
NC2520	FIG-3	20	25	64	51	12	0.13
NC2522	FIG-3	22	25	64	51	12	0.10
NC3204	FIG-1	4	32	85	29.5	M6	0.56
NC3205	FIG-1	5	32	85	29.5	M6	0.53
NC3206	FIG-1	6	32	85	29.5	M6	0.55
NC3207	FIG-1	7	32	85	29.5	M6	0.53
NC3208	FIG-1	8	32	85	29.5	M6	0.54
NC3210	FIG-1	10	32	100	29.5	M8	0.60
NC3212	FIG-1	12	32	100	29.5	M8	0.58
NC3214	FIG-1	14	32	100	29.5	M8	0.55
NC3215	FIG-1	15	32	100	29.5	M8	0.55
NC3216	FIG-1	16	32	100	29.5	M8	0.52
NC3218	FIG-1	18	32	100	29.5	M8	0.49
NC3220	FIG-2	20	32	100	77	14	0.40
NC3222	FIG-2	22	32	100	77	14	0.36
NC3225	FIG-2	25	32	100	77	14	0.28

水孔 Coolant	SHAPE	Dimensions,mm					Weight (kg)
		d	D	L	H	M	
NC25-04A	FIG-4	4	25	64	23.5	M4	0.27
NC25-05A	FIG-4	5	25	64	23.5	M5	0.26
NC25-06A	FIG-4	6	25	64	23.5	M6	0.26
NC25-07A	FIG-4	7	25	64	23.5	M6	0.25
NC25-08A	FIG-4	8	25	64	23.5	M6	0.25
NC25-09A	FIG-4	9	25	64	23.5	M6	0.24
NC25-10A	FIG-4	10	25	64	23.5	M6	0.23
NC25-11A	FIG-4	11	25	64	23.5	M6	0.23
NC25-12A	FIG-4	12	25	64	23.5	M6	0.22
NC25-13A	FIG-4	13	25	64	23.5	M6	0.20

FIG-4

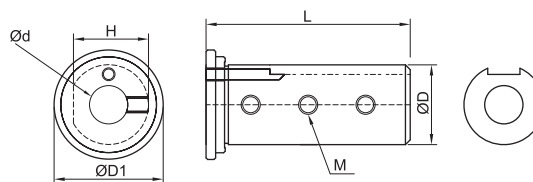

※目錄中規格和工具尺寸如有變更，依實際出貨為主，本公司保有異動權利。
We reserve the right to amend the design or specification of our products.
The final dimensions are subject to our supply.

BORING BARS
內徑車刀
TOOL HOLDERS
外徑車刀
THREADING & GROOVING
牙刀 & 開槽刀
MILLING
銑刀
BORING TOOLS COMPONENTS
孔加工
SPARE PARTS
配件

內徑車刀套筒 SLEEVES FOR BORING BARS



FIG-1

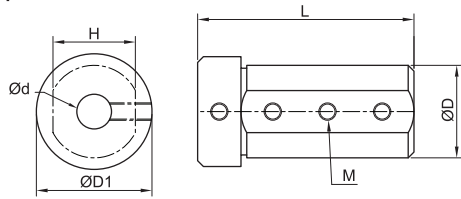

FIG-2

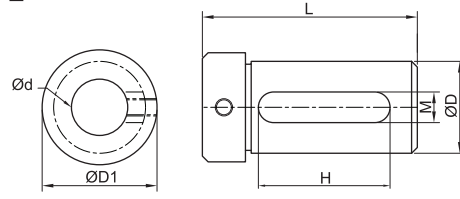

FIG-3

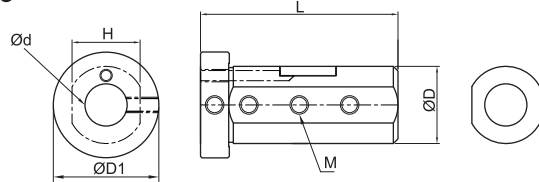
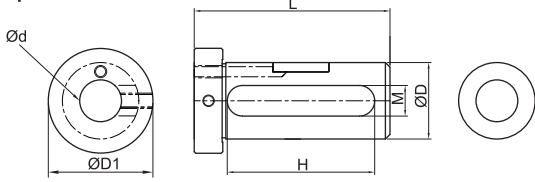

FIG-4



無水孔 Non-coolant	SHAPE	Dimensions,mm					Weight (kg)
		d	D	L	H	M	
NC4005	FIG-1	5	40	100	38	M6	1.03
NC4006	FIG-1	6	40	100	38	M6	1.00
NC4007	FIG-1	7	40	100	38	M6	1.01
NC4008	FIG-1	8	40	100	38	M8	0.99
NC4010	FIG-1	10	40	100	38	M8	0.93
NC4012	FIG-1	12	40	100	38	M8	0.94
NC4014	FIG-1	14	40	100	38	M8	0.90
NC4015	FIG-1	15	40	100	38	M8	0.89
NC4016	FIG-1	16	40	100	38	M8	0.87
NC4018	FIG-1	18	40	100	38	M8	0.83
NC4020	FIG-2	20	40	100	78	14	0.71
NC4022	FIG-2	22	40	100	78	14	0.69
NC4025	FIG-2	25	40	100	78	14	0.60
NC4032	FIG-2	32	40	100	78	14	0.40

無水孔 Non-coolant	SHAPE	Dimensions,mm					Weight (kg)
		d	D	L	H	M	
NC5008	FIG-1	8	50	100	48	M8	1.58
NC5010	FIG-1	10	50	100	48	M8	1.56
NC5012	FIG-1	12	50	100	48	M8	1.53
NC5014	FIG-1	14	50	100	48	M8	1.51
NC5016	FIG-1	16	50	100	48	M8	1.47
NC5018	FIG-1	18	50	100	48	M8	1.43
NC5020	FIG-1	20	50	100	48	M8	1.39
NC5025	FIG-1	25	50	100	48	M8	1.26
NC5032	FIG-2	32	50	100	77	14	0.95
NC5040	FIG-2	40	50	100	77	14	0.71
NC6020	FIG-1	20	60	120	57	M8	2.44
NC6025	FIG-1	25	60	120	57	M8	2.28
NC6032	FIG-1	32	60	120	57	M8	1.98
NC6040	FIG-1	40	60	120	57	M8	1.55
NC6050	FIG-2	50	60	120	102	14	0.87

水孔 Coolant	SHAPE	Dimensions,mm					Weight (kg)
		d	D	L	H	M	
NEW NC40-05AC	FIG-5	5	40	90	38	M6	0.89
NEW NC40-06AC	FIG-5	6	40	90	38	M6	0.89
NEW NC40-08AC	FIG-5	8	40	90	38	M8	0.87
NEW NC40-10AC	FIG-5	10	40	90	38	M8	0.85
NEW NC40-12AC	FIG-5	12	40	90	38	M8	0.83
NEW NC40-16AC	FIG-5	16	40	90	38	M8	0.77
NEW NC40-17AC	FIG-5	17	40	90	38	M8	0.76
NEW NC40-18AC	FIG-5	18	40	90	38	M8	0.74
NEW NC40-20AC	FIG-6	20	40	90	72	14	0.63
NEW NC40-25AC	FIG-6	25	40	90	72	14	0.53
NEW NC40-32AC	FIG-6	32	40	90	72	14	0.36

FIG-5

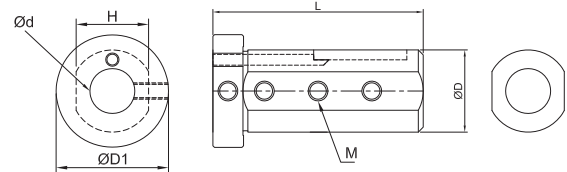
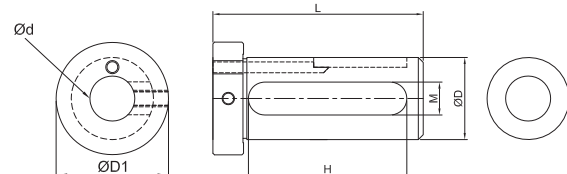

FIG-6



內徑車刀
BORING BARS

外徑車刀
TOOL HOLDERS

牙刀 & 開槽刀
THREADING & GROOVING

銑刀
MILLING

孔加工
BORING TOOLS COMPONENTS

配件
SPARE PARTS

FIG-1

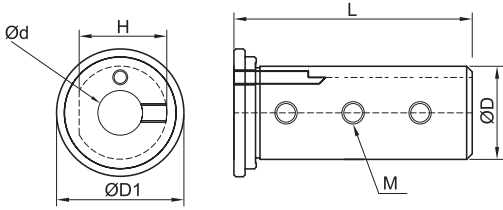
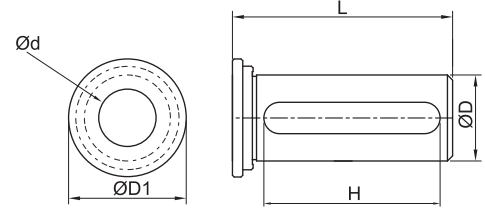
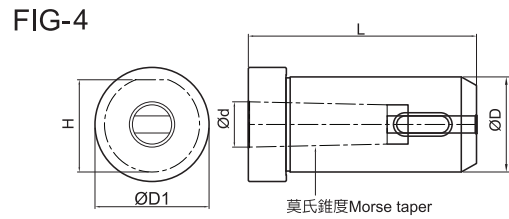
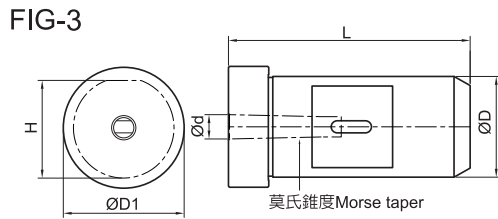
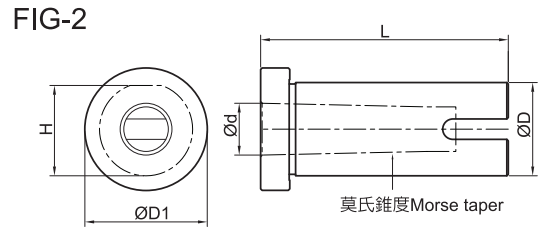
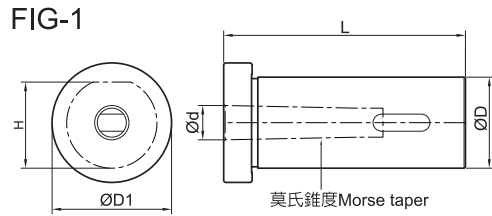

FIG-2



Inch

	無水孔 Non-coolant	SHAPE	Dimensions, mm					Weight (kg)
			d	D	L	H	M	
NEW	NCI 25.4-06	FIG-1	6	25.4	64	23.5	M6	0.17
NEW	NCI 25.4-08	FIG-1	8	25.4	64	23.5	M6	0.16
NEW	NCI 25.4-10	FIG-1	10	25.4	64	23.5	M6	0.13
NEW	NCI 25.4-12	FIG-1	12	25.4	64	23.5	M6	0.10
NEW	NCI 25.4-14	FIG-2	14	25.4	64	12	--	0.18
NEW	NCI 25.4-16	FIG-2	16	25.4	64	12	--	0.17
NEW	NCI 25.4-20	FIG-2	20	25.4	64	12	--	0.12



無水孔 Non-coolant	SHAPE	Dimensions,mm					Weight (kg)
		d	D	L	H	M	
NC25-MTA1	FIG-2	MTA1	25	75	24	--	0.28
NC25-MTA2	FIG-2	MTA2	25	75	24	--	0.23
NC25-MTA3	FIG-2	MTA3	25	90	24	--	0.21
NC32-MTA1	FIG-1	MTA1	32	85	30.8	--	0.53
NC32-MTA2	FIG-2	MTA2	32	85	30.8	--	0.45
NC32-MTA3	FIG-2	MTA3	32	100	30.8	--	0.47
NC40-MTA1	FIG-1	MTA1	40	87	39	--	0.85
NC40-MTA2	FIG-2	MTA2	40	87	37	--	0.75
NC40-MTA3	FIG-2	MTA3	40	87	37	--	0.64
NC40-MTA4	FIG-2	MTA4	40	116	39	--	0.72
NC50-MTA1	FIG-3	MTA1	50	120	48.5	--	1.95
NC50-MTA2	FIG-4	MTA2	50	120	48.5	--	1.83
NC50-MTA3	FIG-4	MTA3	50	120	48.5	--	1.66
NC50-MTA4	FIG-2	MTA4	50	120	48.5	--	1.39
NC50-MTA5	FIG-2	MTA5	50	146	48.5	--	0.94

※目錄中規格和工具尺寸如有變更，依實際出貨為主，本公司保有異動權利。
We reserve the right to amend the design or specification of our products.
The final dimensions are subject to our supply.

內徑車刀
BORING BARS

外徑車刀
TOOL HOLDERS

牙刀 & 開槽刀
THREADING & GROOVING

銑刀
MILLING

孔加工
BORING TOOLS COMPONENTS

配件
SPARE PARTS

FIG-1

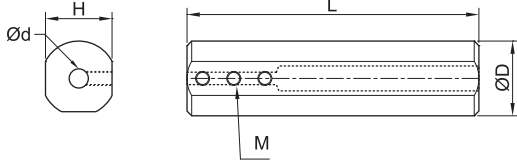

FIG-4

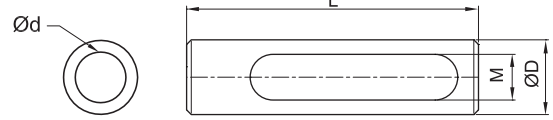

FIG-2

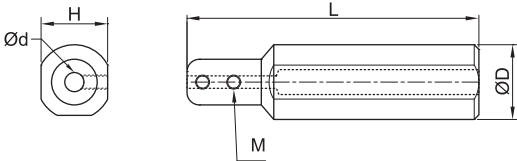

FIG-5

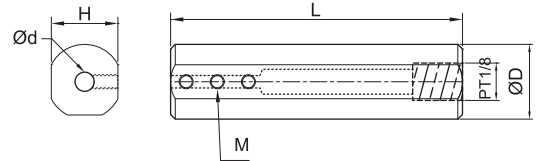

FIG-3

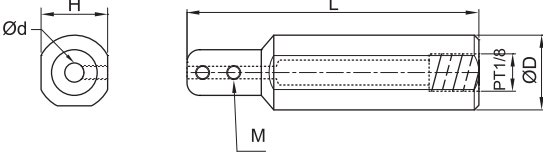
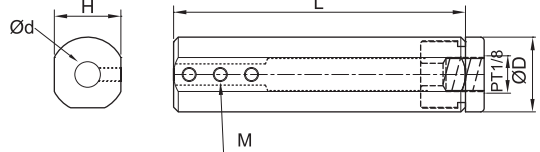

FIG-6



Metric

無水孔 Non-coolant	SHAPE	Dimensions,mm					Weight (kg)
		d	D	L	H	M	
SHB-1602	FIG-1	2	16	100	14	M4	0.13
SHB-1603	FIG-1	3	16	100	14	M4	0.12
SHB-1604	FIG-1	4	16	100	14	M4	0.12
SHB-1605	FIG-1	5	16	100	14	M4	0.12
SHB-1606	FIG-1	6	16	100	14	M5	0.11
SHB-1607	FIG-1	7	16	100	14	M5	0.11
SHB-1608	FIG-1	8	16	100	14	M5	0.10
SHB-1610	FIG-1	10	16	100	15	M4	0.09
SHB-2002A	FIG-2	2	20	100	18	M3	0.20
SHB-2003A	FIG-2	3	20	100	18	M4	0.19
SHB-2004A	FIG-2	4	20	100	18	M4	0.19
SHB-2005	FIG-1	5	20	100	18	M5	0.21
SHB-2006	FIG-1	6	20	100	18	M5	0.21
SHB-2007	FIG-1	7	20	100	18	M5	0.21
SHB-2008	FIG-1	8	20	100	18	M5	0.21
SHB-2010	FIG-1	10	20	100	18	M5	0.16
SHB-2012	FIG-1	12	20	100	18	M5	0.14
SHB-2203A	FIG-2	3	22	100	20	M4	0.24
SHB-2204A	FIG-2	4	22	100	20	M4	0.24
SHB-2205	FIG-1	5	22	100	20	M5	0.27
SHB-2206	FIG-1	6	22	100	20	M5	0.26
SHB-2207	FIG-1	7	22	100	20	M5	0.25
SHB-2208	FIG-1	8	22	100	20	M5	0.24
SHB-2210	FIG-1	10	22	100	20	M5	0.22
SHB-2212	FIG-1	12	22	100	20	M5	0.20
SHB-2214	FIG-4	14	22	100	--	11	0.20
SHB-2216	FIG-4	16	22	100	--	10	0.13

內徑車刀
BORING BARS
外徑車刀
TOOLHOLDERS
牙刀 & 開槽刀
THREADING & GROOVING
銑刀
MILLING
孔加工
BORING TOOLS COMPONENTS
配件
SPARE PARTS

Metric

無水孔 Non-coolant	水孔 Coolant	SHAPE	Dimensions,mm					Weight (kg)
			d	D	L	H	M	
	SHB-2203A PT02	FIG-3	3	22	110	20	M4	0.24
	SHB-2204A PT02	FIG-3	4	22	110	20	M4	0.24
	SHB-2205 PT02	FIG-5	5	22	110	20	M5	0.27
	SHB-2206 PT02	FIG-5	6	22	110	20	M5	0.28
	SHB-2207 PT02	FIG-5	7	22	110	20	M5	0.27
	SHB-2208 PT02	FIG-6	8	22	110	20	M5	0.21
	SHB-2210 PT02	FIG-6	10	22	110	20	M5	0.21
	SHB-2212 PT02	FIG-6	12	22	110	20	M5	0.20
SHB-2503		FIG-1	3	25	100	23	M4	0.37
SHB-2504		FIG-1	4	25	100	23	M4	0.36
SHB-2505		FIG-1	5	25	100	23	M5	0.35
SHB-2506		FIG-1	6	25	100	23	M5	0.35
SHB-2507		FIG-1	7	25	100	23	M5	0.34
SHB-2508		FIG-1	8	25	100	23	M5	0.33
SHB-2510		FIG-1	10	25	100	23	M5	0.31
SHB-2512		FIG-1	12	25	100	23	M5	0.28
SHB-2516		FIG-1	16	25	100	23	M5	0.22
SHB-2520		FIG-4	20	25	100	--	10	0.13

Inch

無水孔 Non-coolant	SHAPE	Dimensions,mm					Weight (kg)
		d	D	L	H	M	
SHBI-19.05-06	FIG-1	6	19.05	100	18	M5	0.20
NEW SHBI-19.05-08	FIG-1	8	19.05	100	18	M5	0.19
NEW SHBI-19.05-10	FIG-1	10	19.05	100	18	M5	0.20
NEW SHBI-19.05-12	FIG-1	12	19.05	100	19	M5	0.19
SHBI-25.4-06	FIG-1	6	25.4	100	23	M5	0.37
SHBI-25.4-08	FIG-1	8	25.4	100	23	M5	0.34
SHBI-25.4-10	FIG-1	10	25.4	100	23	M5	0.33
SHBI-25.4-12	FIG-1	12	25.4	100	23	M5	0.29
SHBI-25.4-16	FIG-1	16	25.4	100	23	M5	0.24
NEW SHBI-25.4-20	FIG-4	20	25.4	100	--	10	0.24

※目錄中規格和工具尺寸如有變更，依實際出貨為主，本公司保有異動權利。
We reserve the right to amend the design or specification of our products.
The final dimensions are subject to our supply.

內徑車刀
BORING BARS

外徑車刀
TOOL HOLDERS

牙刀 & 開槽刀
THREADING & GROOVING

銑刀
MILLING

孔加工
BORING TOOLS COMPONENTS

配件
SPARE PARTS





內徑車刀輔助刀座

LATHE QUICK CENTER BLOCK

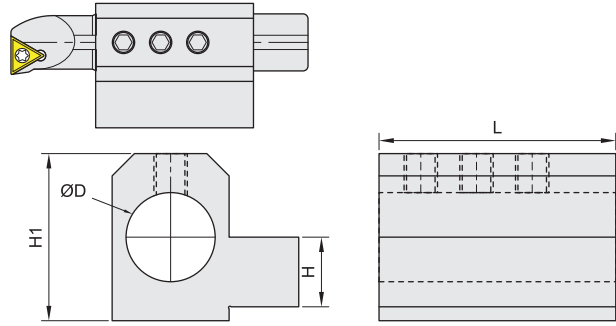

SBHA





Item code	Dimensions,mm				Screw 	Wrench 	Weight (kg)
	H	D	H1	L			
SBHA 16-32	16	32	55	85	HM1216	PL60	1.43
SBHA 20-32	20	32	55	85			1.46
SBHA 20-40	20	40	60	90			1.67
SBHA 25-32	25	32	60	85			1.78
SBHA 25-40	25	40	65	90			2.08
SBHA 32-40	32	40	72	90			2.62

NEW

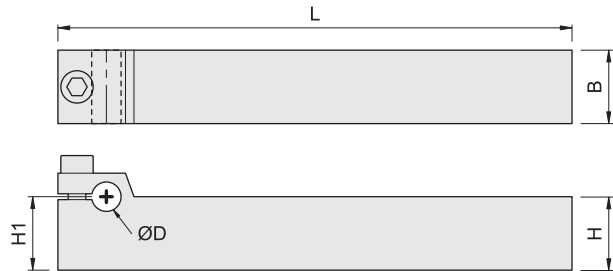
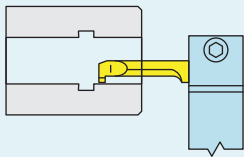
CH



Item code	Dimensions,mm					Screw 	Wrench 	Weight (kg)
	D	H	B	L	H1			
CH-2020K-05	5	20	20	125	20	HTM625	PL50	0.46
CH-2020K-06	6							0.45
CH-2020K-08	8							0.45
CH-2020K-10	10							0.45
CH-2525M-05	5	25	25	150	25			0.84
CH-2525M-06	6							0.80
CH-2525M-08	8							0.80
CH-2525M-10	10							0.80
CH-2525M-12	12							0.80

內徑車刀
BORING BARS

外徑車刀
TOOL HOLDERS

牙刀 & 開槽刀
THREADING & GROOVING

銑刀
MILLING

孔加工
BORING TOOLS COMPONENTS

配件
SPARE PARTS